



**UNIVERSITI KUALA LUMPUR
Malaysia France Institute**

**FINAL EXAMINATION
JANUARY 2014 SESSION**

SUBJECT CODE : FED 10102
SUBJECT TITLE : ELECTRICAL FUNDAMENTAL
LEVEL : DIPLOMA
TIME / DURATION : 3.0 HOURS 9.00 am - 12.00 noon
DATE : 27 MAY 2014

INSTRUCTIONS TO CANDIDATE

1. Please read the instructions given in the question paper CAREFULLY.
 2. This question paper is printed on both sides of the paper.
 3. Please write your answers on the answer booklet provided.
 4. Answers should be written in blue or black ink except for sketching, graphic and illustration.
 5. This question paper consists of TWO (2) sections. Section A and B. Answer all questions in Section A. For Section B, answer two (2) questions only.
 6. Answer all questions in English.
-

THERE ARE 6 PAGES OF QUESTIONS, EXCLUDING THIS PAGE AND APPENDIX.

SECTION A (Total: 60 marks)**INSTRUCTION: Answer ALL questions.****Please use the answer booklet provided.****Question 1**

In **Figure 1**, given the resistors values, $R_1 = 1\text{ k}\Omega$, $R_2 = 3.3\text{ k}\Omega$ and $R_3 = R_4 = 100\ \Omega$:

- (a) Determine the 4-band color code for resistors, R_1 , R_2 , R_3 and R_4 with 5% tolerance. (6 marks)
- (b) Calculate the equivalent resistance, R_{AB} between point A and B. (6 marks)
- (c) Explain briefly Kirchhoff's voltage law (KVL) and Kirchhoff's current law (KCL) (4 marks)
- (d) Define voltage, V and current, I , and state their units (4 marks)

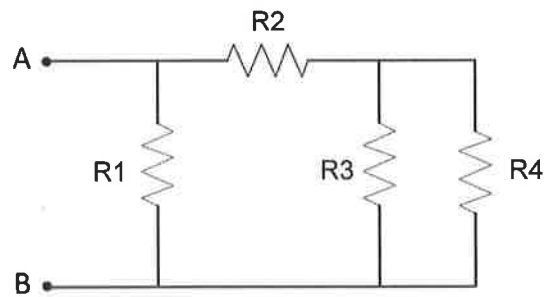
**Figure 1**

Question 2

Based on circuit of **Figure 2**, calculate:

- (a) the currents, i_1 , i_2 , i_3 and i_4 . (6 marks)
- (b) the voltage drop across resistors 10Ω and 30Ω (4 marks)

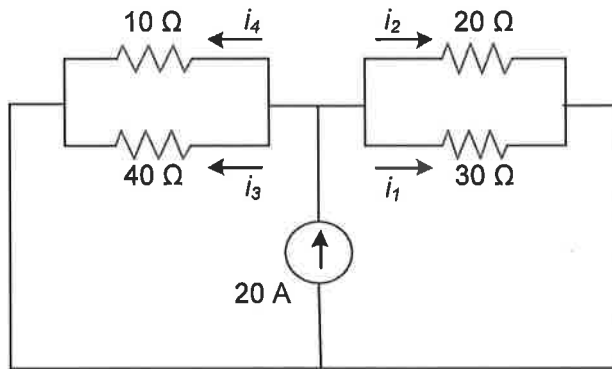

Figure 2

Question 3

Three lamps A, B and C as shown in **Figure 3** are connected in series across an 18 V supply. Lamp A has an internal resistance R_A , lamp B has an internal resistance R_B , and lamp C has an internal resistance R_C . If the total resistance is 36Ω , voltage drop across R_B is $V_B = 5V$, and voltage drop across R_C is $V_C = 3V$, determine:

- (a) The total current in the circuit (3 marks)
- (b) The value of resistances R_A , R_B , and R_C (6 marks)
- (c) Power dissipated on each resistor R_A , R_B , and R_C (6 marks)

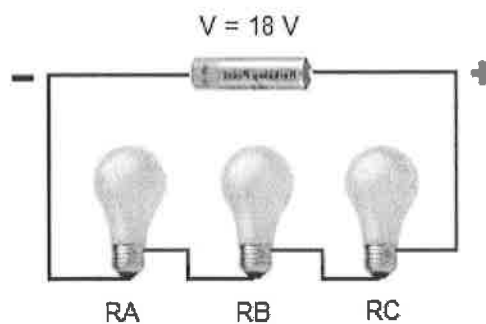

Figure 3

Question 4

Based on the circuit shown in **Figure 4**, fill up **Table 1** with the related values of voltage, current, resistance, and power dissipated. Show all your works.

(Fill-up the answer in Appendix 1 and submit the page with your answer booklet).

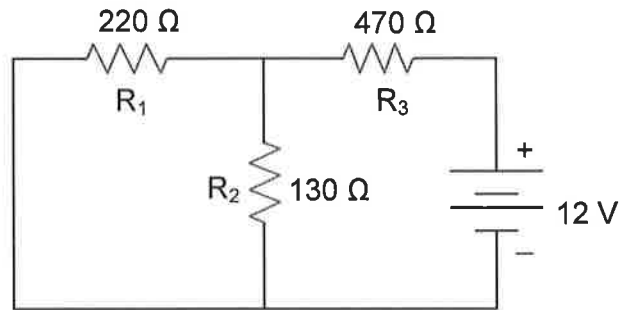

Figure 4

Table 1

	R ₁	R ₂	R ₃	TOTAL
Voltage, V				
Current, I				
Resistor, R	220 Ω	130 Ω	470 Ω	
Power, P				

(15 marks)

SECTION B (Total: 40 marks)**INSTRUCTION: Answer only TWO (2) questions****Please use the answer booklet provided.****Question 5**By using the source transformation method on **Figure 5**:

- (a) Determine the current through the $8\ \Omega$ resistor. Indicate the current direction. (7 marks)
- (b) Determine the voltage, V_o (3 marks)
- (c) Verify your answer in (a) and (b) by using nodal analysis method. (10 marks)

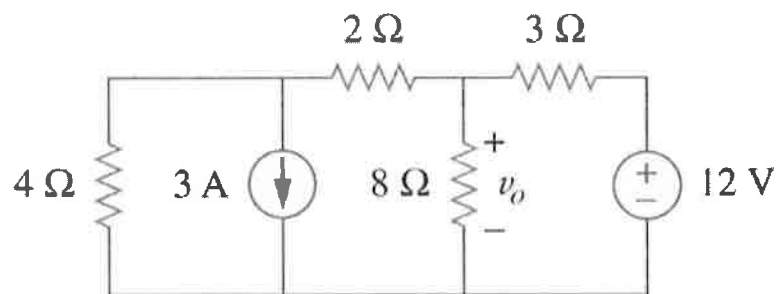
**Figure 5**

Question 6

- (a) Calculate the branch currents I_1 , I_2 , and I_3 in the circuit of **Figure 6** by using mesh analysis technique. Given, the resistance $R_1 = 10 \Omega$, $R_2 = 20 \Omega$, $R_3 = 15 \Omega$ and voltage

$$V_1 = 15 \text{ V}, \quad V_2 = 25 \text{ V}$$

(10 marks)

- (b) Verify your answer in (a) by using superposition theorem

(10 marks)

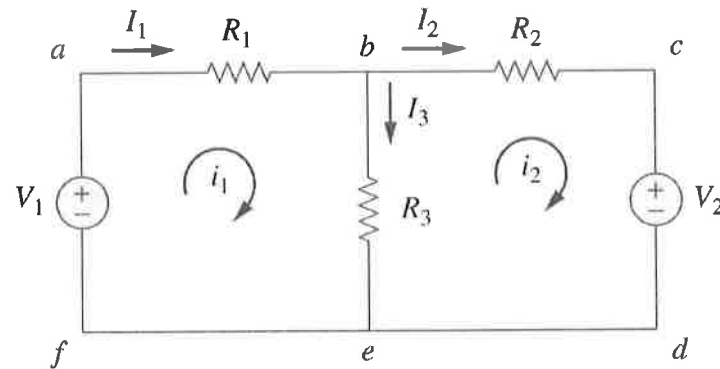
**Figure 6**

Question 7

Based on **Figure 7**:

- (a) Determine the Thevenin equivalent circuit of the circuit shown in Figure 7, to the left of the terminals a-b (10 marks)
- (b) Draw the circuit determined in (a) (4 marks)
- (c) Calculate the current I_L , through load resistor for $R_L = 6 \Omega$ & 36Ω (6 marks)

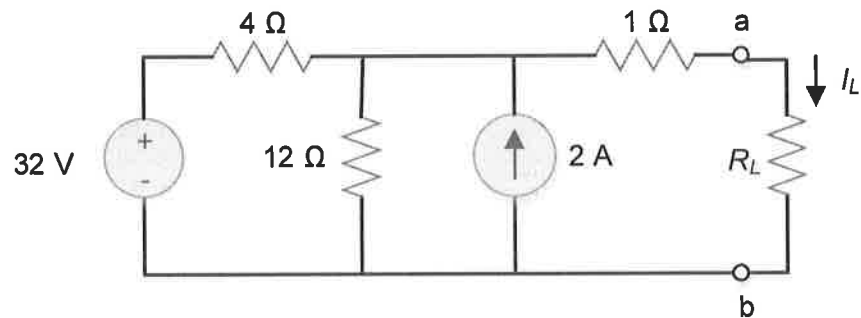

Figure 7

END OF QUESTION PAPER

APPENDIX 1

Answer Table for Question 4

	R ₁	R ₂	R ₃	TOTAL
Voltage, V				
Current, I				
Resistor, R	220 Ω	130 Ω	470 Ω	
Power, P				

(SUBMIT WITH ANSWER BOOKLET)