

# Chapter 29

## Development of Blynk IoT Platform Weather Information Monitoring System



**Muhammad Amiruddin Kamarudin, Noor Hidayah Mohd Yunus,  
Mohd Raziff Abd Razak, Mohd Shahrul Mohd Nadzir,  
and Kemal Maulana Alhasa**

**Abstract** Internet of things (IoT) is a modern technology that connects between physical equipment and some other devices to the Internet network for the desired application. The demand for weather monitoring application leads to an initiative for smart IoT development. There is the issue of an urgent weather alert need for someone who wants to monitor environmental conditions before involving in outdoor activities. Thus, this paper proposes a device of weather information monitoring system to efficiently monitor weather conditions in real time and sending alert notifications via mobile Blynk application, SMS, and email. The device is composed of ESP8266 as microcontroller, temperature-humidity sensor (DHT11), rain drop, and carbon monoxide (CO) detection sensors with integrated real-time data transmit through GSM and Wi-Fi network. The proposed system is designed with a user-friendly GUI mobile application and Web based, accordingly the users can get the updates from the weather monitoring system at anytime and anywhere.

**Keywords** Weather monitoring · IoT · Sensor · Blynk application · NodeMCU · Web based

---

M. A. Kamarudin · N. H. M. Yunus (✉) · M. R. A. Razak  
Communication Technology Section, Universiti Kuala Lumpur British Malaysian Institute, Batu  
8, Jalan Sungai Pusu, 53100 Gombak, Selangor, Malaysia  
e-mail: [noorhidayahm@unikl.edu.my](mailto:noorhidayahm@unikl.edu.my)

M. A. Kamarudin  
e-mail: [amiruddin.kamarudin@s.unikl.edu.my](mailto:amiruddin.kamarudin@s.unikl.edu.my)

M. R. A. Razak  
e-mail: [mrziff@unikl.edu.my](mailto:mrziff@unikl.edu.my)

M. S. M. Nadzir · K. M. Alhasa  
Department of Earth Sciences and Environment, Faculty of Science and Technology, Universiti  
Kebangsaan Malaysia, 43600 Bangi, Selangor, Malaysia  
e-mail: [shahrulnadzir@ukm.edu.my](mailto:shahrulnadzir@ukm.edu.my)

## 29.1 Introduction

The ancient peoples depended on their own experiences, animal actions, and photo-synthetic fruiting to forecast the weather throughout the coming years. In the end of the nineteenth century, weather predictions are completely adaptable depending on observational principles, with no knowledge of weather and specific physical mechanisms [1, 2]. Every planned activity carried out in daily life is strongly influenced by the surrounding weather factors. Weather forecast is important to various sectors such as energy industries, agriculture, transportation department, and automation, and accordingly, weather forecasting is part of the economic progression. There are many situations which has been proven the importance of weather monitoring system in many aspects such as to ensure the stable healthy growth of plants, wind farms, movement in workplace, scheduling for travel trip, and so on. Certainty about weather conditions causes all activities could be run smoothly. There is weather forecast information reported in media, television, and radio; however, the information received is generally for the forecasting of a particular day in a district for the state. Therefore, real-time information updates on weather monitoring system is very affordable in many aspects.

In the world of modernization and technological growth, innovation is important to make ease in daily life [3–5]. Today, a growing demand for various desired applications over the Internet network keeps increasing. IoT enables a wide range of various application devices with identical protocols for coordinating the complete applications interaction [6]. Current technologies such as wireless sensor networks (WSNs), signal processing systems, smart home automation, controlling, and monitoring systems can be enhanced become smarter and more efficient with the association of IoT based [7].

For that reason, this paper aims to develop a moveable weather monitoring device linked with data storage cloud and displaying the information. An application is developed for the users to view in real-time weather information. The data from the connected sensors can be viewed by the users via smartphone with Blynk application, SMS, and email alerts. The sensors used to measure parameters such as humidity and temperature, rain drop, and carbon monoxide (CO). To demonstrate the practicability, the monitoring device is portable where it can be installed, mounted, and accessible from anywhere, to obtain such informational data.

## 29.2 Methodology

### 29.2.1 Project Development

Figure 29.1 shows the block diagram of the weather monitoring system. Figure 29.2 describes the flowchart functionality insights into the system. Firstly, the power supply at 5 V with 1200 mA is required to initialize the system. The connected

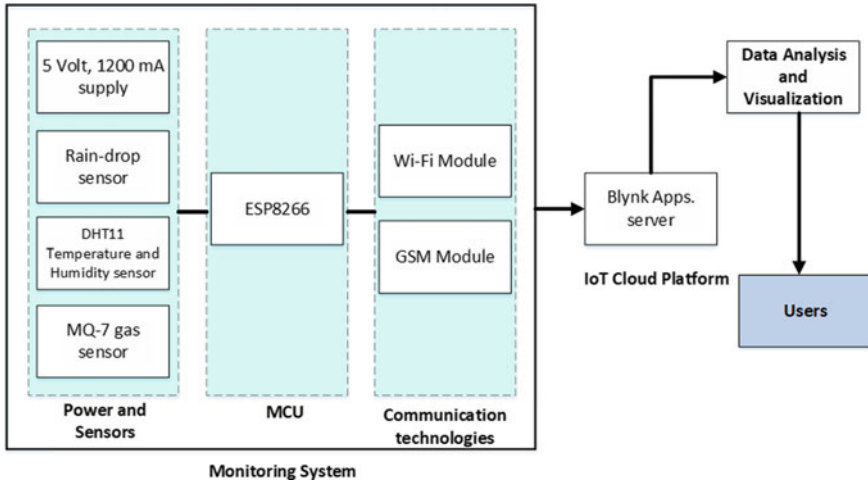

Fig. 29.1 Block diagram of the weather monitoring system

sensors are to ensure in active mode, so that the data from the sensors can be sent to the NodeMCU ESP8266 microcontroller. Arduino UNO SMD Rev3 is used to program the microcontroller. All the data from sensors being forwarded to Blynk server over a GSM and Wi-Fi network. Blynk is one of modern platforms that gives users to develop interfaces basically from iPhone operating system (iOS) and Android computer to track and monitor the desired applications [8]. The collected data are analyzed and employed on data visualization for the end users to receive information updates of the weather conditions.

### 29.2.2 Hardware Component

The developed monitoring system consists of NodeMCU ESP8266 microcontroller as a main controller unit (MCU), sensors such as rain drop sensor, CO sensor, temperature, and humidity sensor. In addition, there are connected devices to the MCU which are GSM and Wi-Fi that are widely used.

The Arduino UNO SMD Rev3 is used an ATmega328-based microcontroller module with 14 optical input/output (I/O) pins. There are also six analog input pins available and a crystal oscillator which has a bandwidth 16 MHz. Some functionality also includes several I/O which consist of an ICSP header, a reset button, a USB link, and a power port [9]. The Arduino UNO SMD Rev3 provides all the microcontroller needs, by connecting to a charging computer with a USB cable to get started with an AC-to-DC adapter or battery.

The rain drop sensor is the most important part as a rain sensing tool. There are two components in the sensor, which are a weather board sensing a control module and the

**Fig. 29.2** Flowchart of system

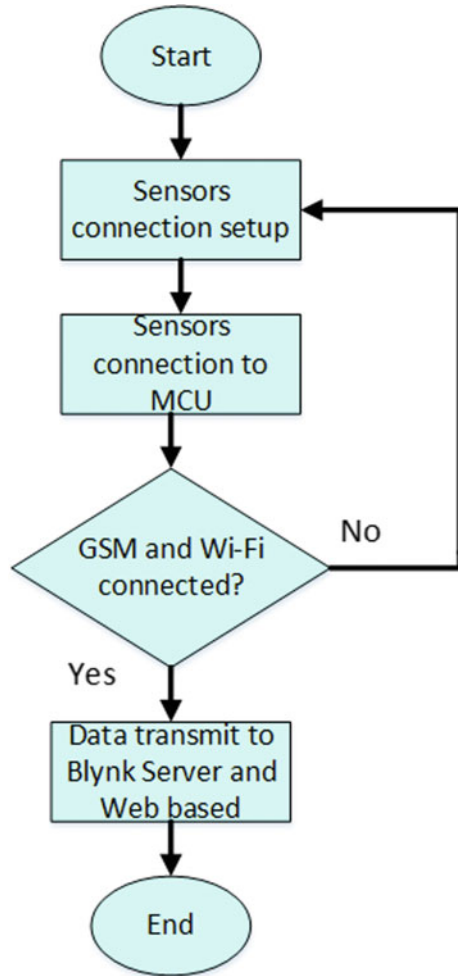

rain comparing and translating the analog value to a digital value. In the automobile industry, rain drop sensors can also be used to remotely control windscreen wipers [10]. In the agricultural sector and in home automation systems, rain drop sensors can be used to automatically track the rain water distribution.

The CO sensor used can be applied to detect various CO containing gases and is suitable for various applications. Besides the sensor detects low and high temperatures by the cycle process and detects CO at low temperatures which is heated by 1.5 V. The conductivity of MQ-7 sensor is greater as the concentration of gas increases.

The DHT11 is a sensor for temperature and humidity that is widely used in sensing weather parameters. The sensor is also able to be mounted to other microprocessors

easily. The sensor provides the features of an 8-bit microcontroller and temperature measurement for the output of serial relative humidity and temperature value data.

### 29.2.3 Software Development

The functionality of the system includes integrating the peripheral devices with software. Figure 29.3 shows the circuit diagram of the weather monitoring system. The monitoring system includes several sensors, communication connectivity, and MCU programmable by Arduino UNO SMD Rev3 as the main part of the weather monitoring system. All of the virtual connections and hardware components are to be synchronized with the Blynk application. Besides, Arduino IDE application was used as an editor to develop the coding called sketch that allows the system to work, whenever a signal for a hazardous weather condition is detected. Once coding is successfully verified and compiled, the codes will be uploaded to the NodeMCU via the serial interface of the MCU. The sketch will allow all the sensors to send the sensed data to the NodeMCU. NodeMCU will process all the data collected and upload it to Blynk application via the Wi-Fi connection. The data are delivered to the OLED display module, and Blynk application. Furthermore, the data are analyzed

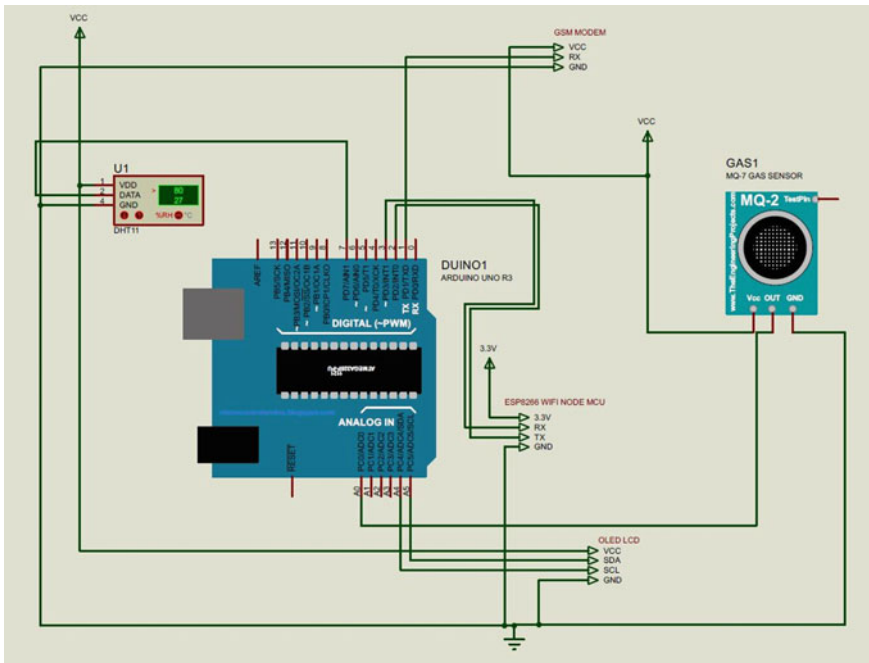

Fig. 29.3 Circuit diagram of system

and employed on data visualization for the end users to receive information updates of the weather condition based on notification alert.

The reliability data measurements for temperature, humidity, percentage of rain, and CO concentration from the sensors during the monitoring application were observed. The information data such as time, temperature in degree Celsius ( $^{\circ}\text{C}$ ), percentage humidity, percentage rain drop, and air quality index (AQI) by CO percentage were extracted from Blynk application. Then, the data are sent to OLED, SMS, and email notifications.

### 29.3 Results and Discussion

Figures 29.4 and 29.5 show the circuit connection for the device prototype of the monitoring system. For data collection, the device is placed at outdoor environment. All of the data were recorded by the Blynk application. Figure 29.6 shows OLED display module in which displaying the data collected from all sensors. In case the air quality index (AQI) value is  $\geq 300$ , the surrounding is considered hazardous, and an emergency alert is likely to be issued. In normal room temperature conditions as the rain drop sensor is dry and not covered by any rain drop, the average values of temperature, humidity, and rain drop percentage are at  $31^{\circ}\text{C}$ , 71%, and 1.07%, respectively. The rain drop percentage at  $\geq 40\%$  is programmed as heavy rain condition; thus, a preparatory step by alert notification is sent through mobile applications.

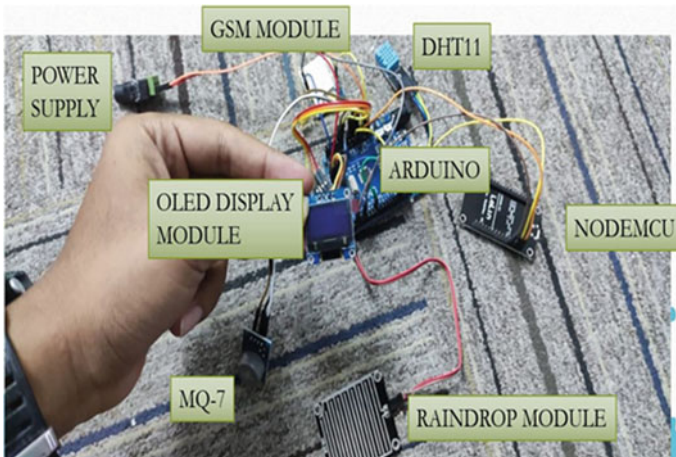

**Fig. 29.4** Circuit connection

**Fig. 29.5** Project prototype



**Fig. 29.6** Information data display on OLED



Figures 29.7 and 29.8 show the graphical user interface (GUI) of the real-time data collected by all the sensors based on normal and high AQI value situations, respectively. The Blynk application interface displayed the updated data instantaneously.

Figure 29.9 shows the alert notification message from the weather monitoring system from GSM module. The notification of abnormal conditions such as ‘It’s raining heavily!!’ and ‘Abnormal air quality index!!’ will pop-up whenever a certain parameter is not in agreement with the normal conditions. Figure 29.10 shows the

**Fig. 29.7** GUI for normal data



notification by email from the Blynk application. The message displayed is similar to the alert notification from SMS via GSM.

### 29.4 Conclusion

In this paper, the development of an IoT-based weather monitoring device system using Arduino UNO SMD Rev3 is presented. The device does not require to have continuing maintenance for the system functionality, thus save labor cost. Several achievements of the development were accomplished, including (1) the information



**Fig. 29.8** GUI for high AQI data

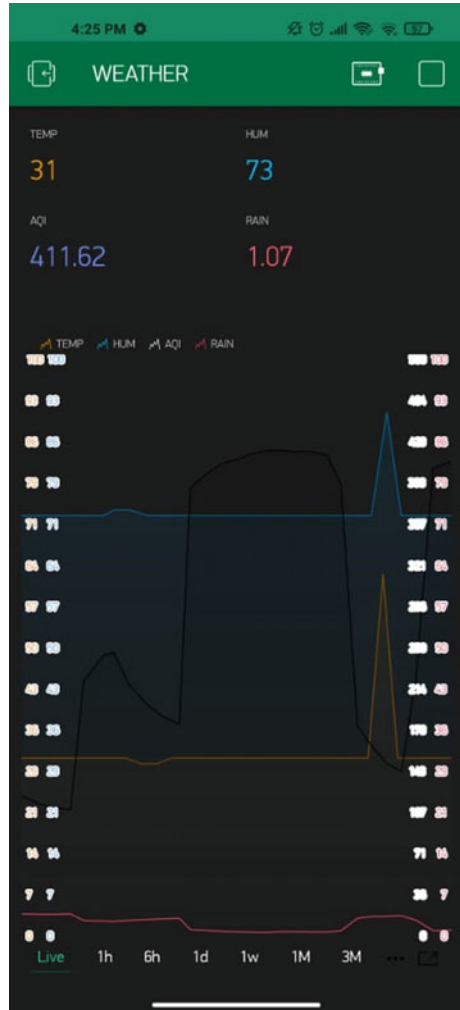

data such as temperature, humidity, rain, and AQI of CO was successfully transmitted from all the sensors to the OLED and mobile application. By this, the user could manage any activities properly, (2) the system used Arduino as a microcontroller associated with Blynk application was able to effectively display all the data information in a real-time basis, and (3) the GUI development through mobile application allowing easy alert notification platform by the user to monitor the weather conditions at anywhere.

According to the final model of the device system, significant advancements in hardware design can be implemented in order to produce better results and commercialized on a worldwide scale. Future work should be conducted to research on the

**Fig. 29.9** SMS alert notification

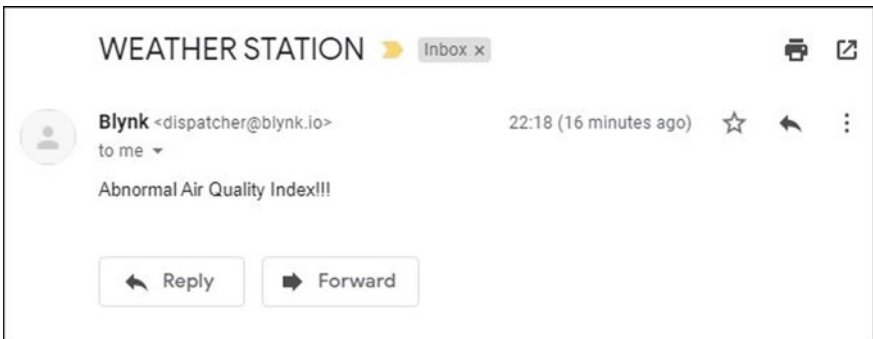
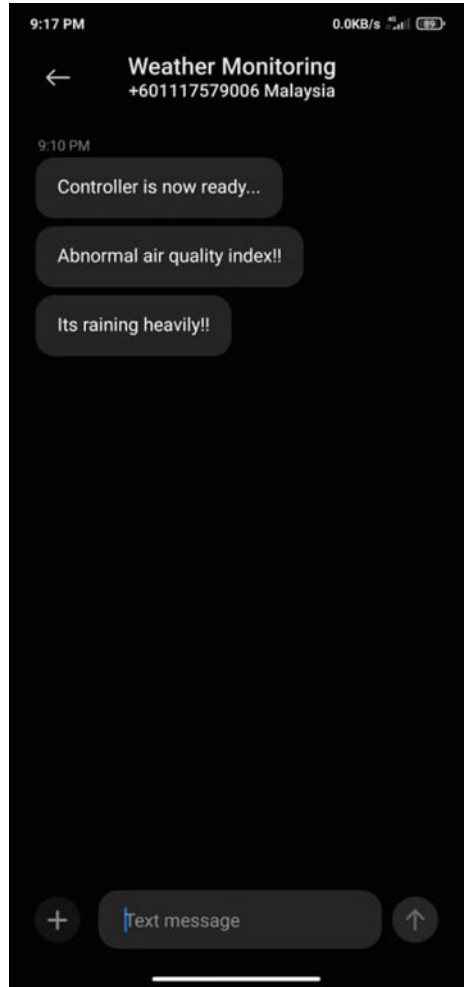

**Fig. 29.10** Email alert notification

sensitivity enhancement of the sensors and adapting long range (LoRa) communication technology connectivity as low power and long range technology capabilities preference.

**Acknowledgements** The authors wish to thank UniKL and Earth Sciences and Environment research team of UKM for the support given in facilitating and contributing to the success of this project.

## References

1. Wiston M, Mphale KM (2018) Weather forecasting: from the early weather wizards to modern-day weather predictions. *J Climatol Weather Forecast* 6(2):1–9
2. Zhu AW, Pi H (2014) A method for improving the accuracy of weather forecasts based on a comprehensive statistical analysis of historical data for the contiguous United States. *J Climatol Weather Forecast* 2(1):1–4
3. Sampe J, Yunus NHM, Yunas J et al (2019) Architecture of an efficient dual band 1.8/2.5 GHz rectenna for RF energy harvesting. *Telkomnika* 17(6):3137–3144
4. Sampe J, Yunus NHM, Yunas J et al (2017) Ultra-low power RF energy harvesting of 1.9 GHz and 2.45 GHz narrow-band rectenna for battery-less remote control. *IJIEE* 7(3):118–122
5. Yunas J, Yunus NHM, Sampe J et al (2020) Design and fabrication of glass based mems patch antenna for energy harvester. In: 2020 IEEE international conference on power and Energy (PECon), pp 362–365
6. Al-Sarawi S, Anbar M, Alieyan K et al (2017) Internet of things (IoT) communication protocols. In: 2017 8th International conference on information technology (ICIT), pp 685–690
7. Kumar NM, Mallick PK (2018) The Internet of things: insights into the building blocks, component interactions, and architecture layers. *Procedia Compu. Sci* 132:109–117
8. Serikul P, Nakpong N, Nakjuatong N (2018) Smart farm monitoring via the Blynk IoT platform: case study: humidity monitoring and data recording. In: 2018 16th International conference on ICT and knowledge engineering (ICT&KE), pp 1–6
9. Seneviratne P (2017) Getting ready for the development environment. In: Building Arduino PLCs, Apress, Berkeley, CA, pp 1–22
10. Rabiei E, Haberlandt U, Sester M et al (2013) Rainfall estimation using moving cars as rain gauges—laboratory experiments. *Hydrol Earth Syst Sci* 17(11):4701–4712