

PAPER • OPEN ACCESS

Non-Oriented Electrical Steel Sheet: The Magnetic Properties Losses on Thickness Lamination Using Epstein Tester Frame

To cite this article: Yanawati Binti Yahya *et al* 2020 *IOP Conf. Ser.: Mater. Sci. Eng.* **864** 012205

View the [article online](#) for updates and enhancements.



240th ECS Meeting ORLANDO, FL

Orange County Convention Center Oct 10-14, 2021



Abstract submission due: April 9

SUBMIT NOW

Non-Oriented Electrical Steel Sheet: The Magnetic Properties Losses on Thickness Lamination Using Epstein Tester Frame

Yanawati Binti Yahya¹, Mohd Khairil Rahmat¹, N. S. Shariffuddin²

¹Renewable Energy Research Laboratory (RENERAL), Electrical Engineering Section, British Malaysian Institute, Universiti Kuala Lumpur, 53100 Gombak, Selangor Malaysia.

²Department of Electrical Technology Engineering, University Kuala Lumpur (UniKL) British Malaysian Institute, 53100 Gombak, Selangor Malaysia.

Email: mkhairil@unikl.edu.my

Abstract: Reducing lamination thickness of steel sheets can reduce the overall loss especially in core loss and copper loss. These research paper shows the impact of lamination thickness on the voltage induced of power loss for the Non-Oriented Electrical Steel Sheet. This study was conducted by using Epstein test which is an outflow of flux investigated throughout the measurement of power loss at corner and limb likewise for each thickness. This data shows and is presented based on different frequency such as 45 Hz, 50 Hz and 55 Hz. It indicates that 0.50 mm lamination thickness has a lot of losses instead of 0.35 mm.

1. Introduction

Previous researcher has been proposed to explain more about the effect of nominal power loss on material (electrical machine design) by using Epstein Tester Frame. Md. Reza Mohyin et al. [1] mentions about the effect of lamination thickness in power loss for non grain material. In these research paper, the Epstein test frame are adjusted for both material and data are presented based on 50 Hz. Flux outflow that have been investigated during the measurement of power loss in the corner and limb as well. It shows that the thickness of 0.50 mm has more losses than 0.35 mm. This supported by Azuddin et al. [2] in their paper title “Nominal Power Loss on Both Thicknesses of Non-oriented Electrical Steel Sheets Using Epstein Test” who content that the alleviating the thickness of steel sheets will reduce the amount of losses mainly in core loss and copper loss. These papers find out a thickness effect in the loss of power for the non-oriented electrical steel sheets. The study was carried out by using the Epstein Test framework for both lamination thickness. Data is obtainable based on 50 Hz. It shows that the 0.50 mm thickness has more losses than 0.35 mm.

Many theories have been proposed to explain more about magnetic properties for induction motor. A J Clerc and A Muetze [3] argued about the magnetic differences from stator begin to end nearly completely due to changes in raw materials. It is still important to note that the manufacturing differences are important and can be detected to the proposed measurement. These machine test makes it ideal for machine manufacturers who want to evaluate their manufacturing process and control the core quality of magnetic packs. This supported by Rodrigues et al. [4] who contend that the outcome of SB content and reduces the cold rolling reduction at core losses at 1.5 T / 50 Hz (W15/50) and magnetic induction (B50) were presented. It can be noted that the best core loss and induction magnetic value



arises around 0.045% of SB and 76% of CDR. This decision can be predicted by structural analysis and it is due to increased texture factors after the last annealing. It can be predicted that the best magnetic property can be found on the final thickness of 0.35 mm which is reduced from 0.95 mm using hot band thickness. Li et al. [5] mentions about the steel sheet of Fe is 6.5 wt.% and Si are 0.3 wt.% Aluminium as-cast was produced by twin-roll strip casting process and then dried with hot & warm rolling, and annealing. A detailed study on the evolution of microstructures and texture at different processing stages was carried out by copies of the optical microSD, X-ray diffusing, and an electron-based backscattered analysis that dispersed. Subsequently, Zu et al. [6] comprehensive their analysis and revealed that the microstructure, texture, and magnetic properties of SI-4.5 wt.% of the electric steel designed by double-roll casting process, hot-rolling, and final disciplines. They are methodically explored with the aim of introducing an incredible electrical steel and promise to various potential requests.

At temperature at 20 Celsius, the conductivity is 0 (S/m) and relative permittivity is 1. The iron loss curves are shown in figure 1 at 20 Celsius of temperature and 50 Hz of frequency. Figure 1 shows that when the flux increases so the iron loss has been increased. The losses are in term of iron loss, hysteresis loss, and eddy current loss. With understanding, this type of material is suitable to design on induction motor because it has lower of power loss total.

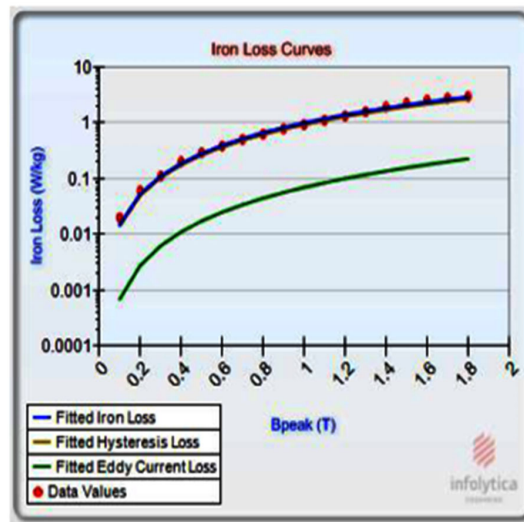

Figure 1. The iron loss (W/kg) Vs. flux (Tesla) for iron loss curves [7].

The finding is that the core iron will increase the magnetic power used in freerolling material and included in the transfer and stationery of Motor and generators. At the earliest, cast iron and iron of the cloud were used because it was simple and available. Cast iron scalability is not actual good because the value of flux density is low compare to other as seen in figure 2. The solid cores were used in the machine causes heavy penalties in the form of eddy loss current of manufacturing subsequently that the product develops the metal industry that has been put into machine core. The core of the solid iron is an electrical conductor and acts as a short-circuit of the strong flow arising from the magnetization change. By making the core using a thin wedge pile or wire package until eddy current loss is reduced.

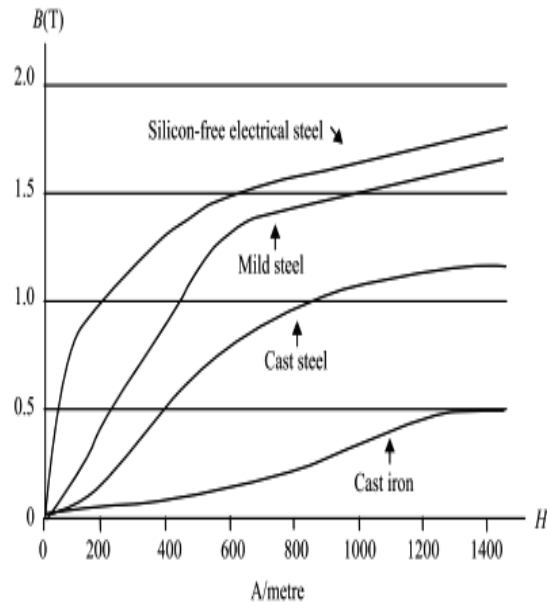

Figure 2. Magnetisability of materials by moderate applied field [8].

Philip Beckley [8] in his book “Electrical Steels for Rotating Machines” found that the framework of a steel strip process itinerary. Figure 3 shows the steel casting and slabbing process.

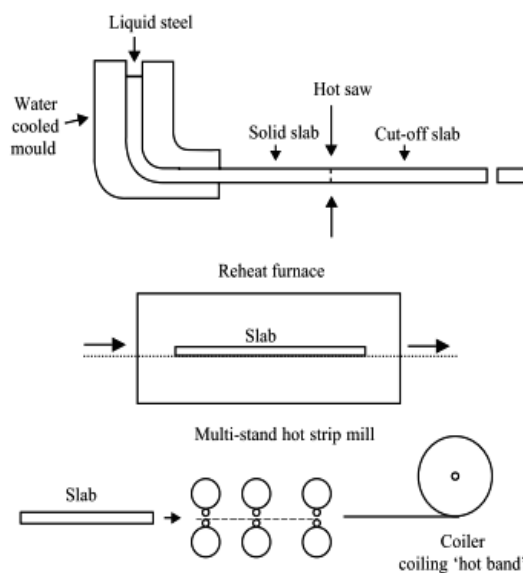

Figure 3. Steel casting and slabbing process [8].

Based on figure 3, the process shows the liquid steel continues to be cast into a hot slab rolling down in range 2 mm until 4 mm thick coil. These coils were called ‘hot band’. The hot rolling process has been used to reduce the thickness that is less than 2 mm is inaccurate due to proper thickness control and good surface conditions that are more difficult to maintain and treatment when persistent cold. Some

hot mills can reach 0.7 mm to 1.0 mm for hot rolled gauge, but this is not common.

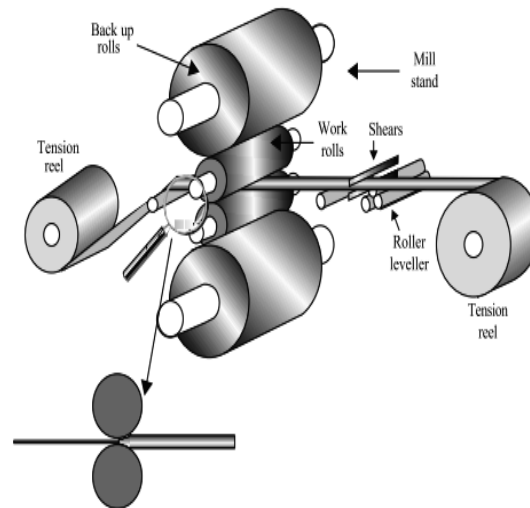

Figure 4. The schematic of cold rolling mill process [8].

Modern cold mills process takes in hot band coils and roll and continue to make them thinner and have final thickness around 0.2 – 0.7 mm as shown in figure 4. Based on figure 4, firstly, the coils will be exposed to a shot of blast, side-trim, and pickling process to remove the scale and provide the appropriate surface for cold rolling. A Strand Anneal can lead cold first rolling for a metal internal structure homogenise. In a Strand anneal steel coils are fed into a long furnace as not launched, then cool down again on the remote end. Furnace can be hundreds of length meters.

According to Beckley P. (2002), in his book, “Steel Electrical: Rotating Machines” in Chapter 6 (page 69 ~ 73) was described the properties of material for rotating machine are made in itemized and used on the decoration of properties and applications as listed:

1. **Composition** Normally, the silicon added is in range from 0 to 3+ %. If silicon rises to be higher so it restrains eddy currents can be reduces loss. If the silicon content more than 3+ % so the lamination will be harder and more expensive.
2. **Thickness** The eddy current is more effective on the thinner lamination steel and restrained to the lower of core losses. The effect of thinner lamination steel is to reduce the effective of flux density saturation (B_{sat}). The core losses are relationship between the electrical result and magnetic field.
3. **Hardness** Material can be soft due to being finally annealed and having very little alloy content or progressively harder as the silicon added up to 3%, the phosphorous is added up to 0.08% and temper rolling is applied.

An overview of a set of materials with property range. And included a high-tensile grade which is used in those parts of large machines the mechanical strength is important but reasonable regard must be given to magnetic permeability since flux must be conducted.

Table 1. The selection of electrical steel sheet formed by European Electrical Steels – characteristic properties [1].

Evaluation Identity	3.2 % Si	2% Si	1% Si
Thickness (mm)	0.35	0.50	0.65
Typical specific total loss (W/kg)	2.35	2.38	3.15
Typical specific apparent power (VA/kg)	23	19	14
Nominal silicon content (%)	2.9	2.4	1.3
Resistivity ($\mu\Omega\text{cm}$)	55	59	55
Stacking factor	95	97	97
B (T)	1.53	1.56	1.73

There are two main constituents of the core losses such as the hysteresis and eddy current losses. Charles I. Hubert [9] argued that the first part for core loss is hysteresis loss. The replacement voltage is connected to the magnetizing coil and the magnetomotive power that causes the magnetic domain to be constantly reorganized along the magnetizing axis. These molecular movement produced heat and harder steel. The power loss due to hysteresis for a given type and volume of core material varies directly with the frequency and the n^{th} power of the maximum value of the flux density wave. Expressed precisely as equation (1).

$$P_h = k_h \cdot f \cdot B_{max}^n \quad (1)$$

Where P_h is the hysteresis loss (W/unit mass of core), f is the frequency of the flux wave (Hz), B_{max} is the maximum value of flux density wave (T), k_h is the constant value, n is the steinmetz exponent² which is equal to 1.6 (value for silicon steel sheets).

2. The measurement of power loss via Epstein test

These sections discuss the methodology carried out during experimental setup. The tests have been done are Epstein Test as shown in figure 5. These is to determine the nominal power loss for lamination thickness of steel sheets with harmonic range from fundamental to harmonic 9.

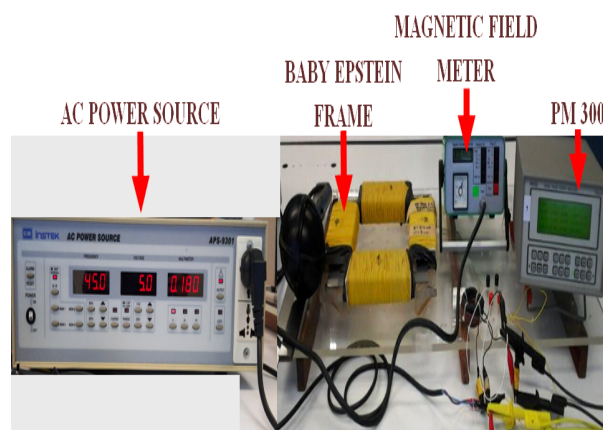
**Figure 5.** Experimental setup for Epstein test

Power loss is missing energy during cycling on the frequency of magnetic steel condition and end of final induction application. Although the data used for the whole range of work encouragement and frequencies is important and available. Primary grade assessment taken as steel performance at a range between 45 Hz until 95 Hz and at B equal to 1.5 T. Epstein Test functions to measure the core lamination of nominal power loss as shown in figure 6. Figure 7 below shows the total of layers are used in this test is 2 layers.

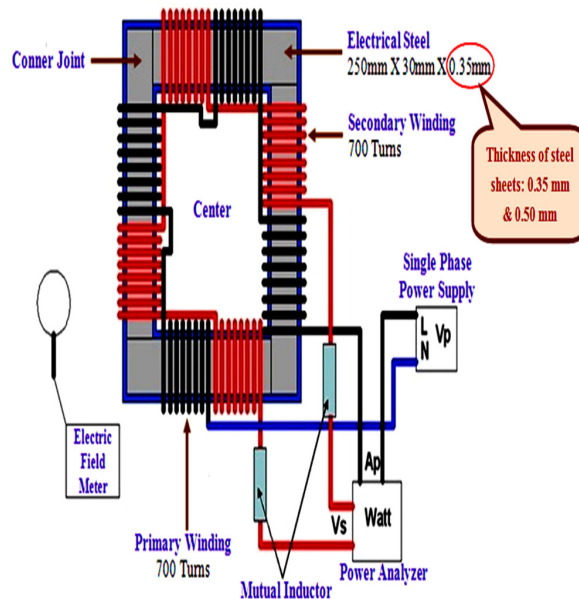

Figure 6. An Epstein test diagram.

Figure 6 shows the Epstein test was elaborate a winding of magnetizing at 700 turns spread over 175 turns / limb of the square. The sample is attained to desire the flux density. The flux density is measured thru voltmeter and connected to the square secondary winding (700 turns). The voltage on the second winding is used to feed the wattmeter which is now excited with the current in the main order of the square. The value of voltage can be calculated with the equation (2).

$$V = 4.44 \times B \times N \times f \times A \quad (2)$$

Where B is flux density (Tesla), N is the number of turns (700 turns), f is the frequency (50 Hz), A is the cross-sectional area which is ($A = \text{width} \times \text{thickness} \times \text{layer}$), and V is the voltage.

Figure 7 shows steel stripe arrangement for 2 layers into the frame of Epstein Test. Each of the lamination sheet involves of 4 strips of electrical steel bands and are stacked together, but together in shared angles at corner joint.

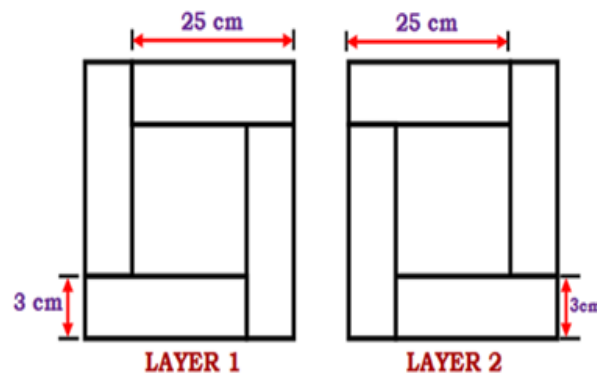

Figure 7. The steel sheets strip lamination with dimension.

Based on figure 7, the length and width of steel sheet strip was used to measure for both thickness such as 0.35 mm and 0.50 mm. The dimension of length and width for each steel sheet strip for both thicknesses are 25 cm and 3 cm. The weights for 12 strips of steel sheets are 0.128 kg for 0.35 mm and 0.228 kg for 0.50 mm.

3. Result and Discussion

3.1 The measurement of power loss for non-oriented electrical steel sheet using Epstein test

From the experimental test, the result displays the power loss, corner flux leakage, limb flux leakage and harmonic factor was increase when flux density increases for both thickness lamination of rotor frame. Based on the experiment part using Epstein test, the analysis and comparison of the results between two different thicknesses lamination for rotor frame which are 0.35 mm and 0.50 mm was described in many aspects such as the graph of power loss, flux leakage at corner, flux leakage at limb and harmonic factor with same frequency at 50 Hz and different frequency at 45 Hz, 50 Hz and 55 Hz.

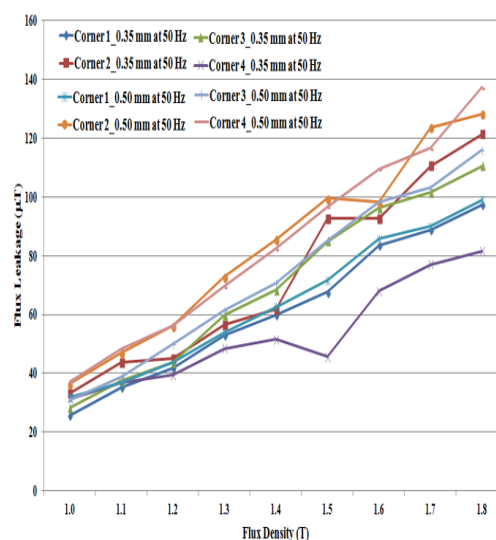

Figure 8. The flux leakage (μT) at corner versus flux density (T) at 50 Hz for both thicknesses.

The corner flux leakage was plotted as shown in figure 8. Figure 8 shows that the flux leakage (μT)

at corner versus flux density (T) at 50 Hz for both thicknesses. Based on that graph, during operation mode in 1.5T for both thickness lamination at 50 Hz of frequency, the value of leakage flux at C1, C2, C3 and C4 are shown in table 2.

Table 2. The data of flux leakage at corner during operation mode in 1.5T for both thickness laminations at 50 Hz.

	0.35 mm (μT)	0.50 mm (μT)	Diff. (%)
Corner 1	67.6	71.6	5.6
Corner 2	92.6	99.6	7.03
Corner 3	84.9	85.1	0.24
Corner 4	45.8	96.7	52.6

Based on table 2, the leakage flux at corner 2 is high compare with others for 0.35 mm thickness. This factor causes by the air gap that is higher from another corner. With an increase and produce more vibration if a flux density increases. The flux leakage (μT) grew rapidly by increasing the flux density (T). Even for the 0.50 mm steel sheet, the air gap on angle 1 is lower than the other angle. This is because of corner/angle 1 has lesser flux leakage.

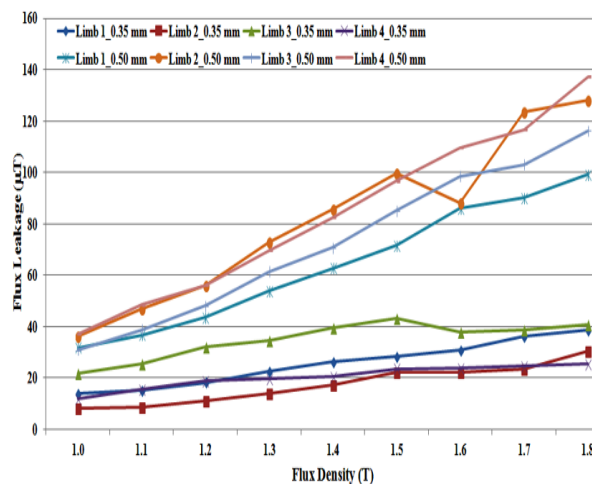

Figure 9. The limb flux leakage (μT) versus flux density (T) for both thicknesses at 50Hz.

Figure 9 shows the limb flux leakage (μT) versus flux density (T) for two lamination thickness at 50 Hz of frequency. Based on that graph, during operation mode in 1.5 T for both thickness lamination at 50 Hz, the value of leakage flux at Limb (L) 1, L2, L3 and L4 will show in table 3.

Table 3. The data of flux leakage at limb during operation mode in 1.5T for both thickness laminations at 50 Hz.

	0.35 mm (μT)	0.50 mm (μT)	Diff. (%)
Limb 1	28.5	71.6	60.2
Limb 2	22.3	99.6	77.6
Limb 3	43.3	85.1	49.1
Limb 4	23.6	96.7	75.6

Based on table 3, the flux leakage (μT) of 0.35 mm thickness is rising progressively with increase the flux density (T). Thru process mode in 1.5 T at 50 Hz, the flux leaked for limb (L) 3 is high compared with others. This reason was due to higher air gaps compared to other limbs. It rises and will produce more vibration when the density of the flux increases. Unlike for 0.50 mm thickness, the limb 1 air gap is less than limb 2, 3 and 4. It is because of limb 1 has lesser flux leakage.

From observation, based on table 2 and table 3, the flux leakage at the corner and limb of induction motor core material are measure by using the electric field meter. From experiment, the different value at corner and limb of induction motor core material was different. It is because of the flux flow through the induction motor core material is random and the change depends on the domain of induction motor core material.

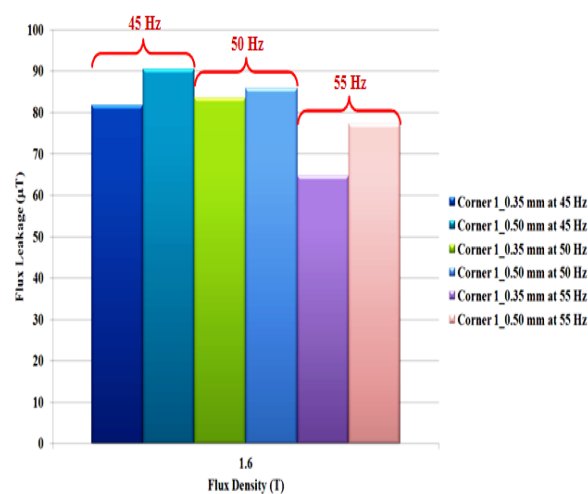

Figure 10. The corner 1 flux leakage (μT) vs. flux density (1.6 T) at different frequency for both thicknesses.

Figure 10 shows the corner 1 flux leakage (μT) versus flux density at 1.6 T for both thicknesses with different frequency such as 45, 50 and 55 Hz. Based on figure 10, the corner leakage flux at 45 Hz for 0.50 mm thickness is high compare with others frequency for both thicknesses. This factor is due to the air gap for this angle in 45 Hz is higher than other frequencies. It develops and produces more vibration when the density of the flux increases.

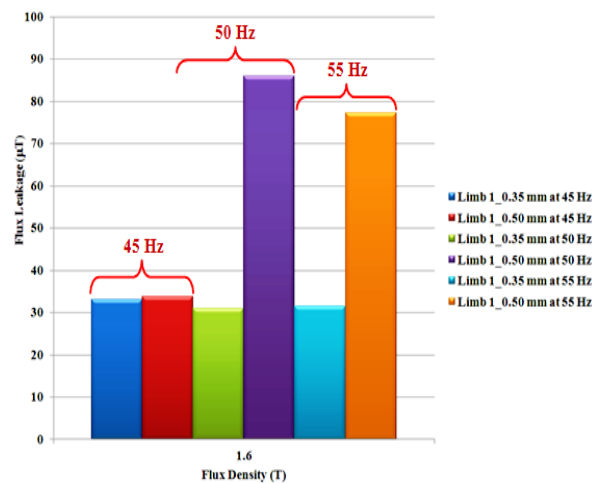

Figure 11. The limb 1 flux leakage (μT) versus flux density (1.6 T) at different frequency for both thicknesses.

Figure 11 shows the limb 1 flux leakage (μT) versus flux density at 1.6 T for both thicknesses lamination at 45 Hz, 50 Hz and 55 Hz. From figure 11, during operation mode in 1.6T at 50 Hz, the leakage flux for limb 1 for 0.50 mm lamination thickness at 50 Hz is high compare with others frequency for both thicknesses. This factor is due to the air gap is high than L2, L3 and L4. It's growing and produces more vibration when the flux density rises.

From observation, based on figure 10 and figure 11, when the material is thin, the air gaps may open up at corners due to sag in the limb length. Then small weights up to 100 g are sometimes applied to each overlap corner. It is because of the butt joint of electrical steel strip at corners represented significant magnetic reluctance, but with the main limbs 25 cm long this effect was not insignificantly faulty.

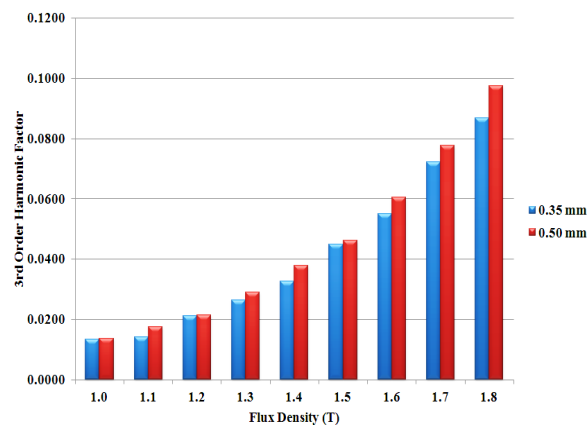

Figure 12. The bars graph of the 3rd harmonic factor versus flux density (T) at 50 Hz for both thicknesses.

Figure 12 was showed the bars graph of 3rd harmonic factor versus flux density for both lamination at 50 Hz. From figure 12, at 50 Hz, throughout the flux density from 1.0 T to 1.8 T, the 0.35 mm 3rd harmonic factor is lower than 0.50 mm lamination thickness with 3% SiFe of steel sheet. At 1.6 T, the value of 0.35 mm 3rd harmonic factor is less compared to 0.50 mm lamination thicknesses of steel sheet

which are 5.49% and 6.05%, respectively. The 0.35 mm has lower of 9.27% compared to 0.50 mm thicknesses for 3rd harmonic factor. It is due to higher loss can increase the harmonics of an induction motor material.

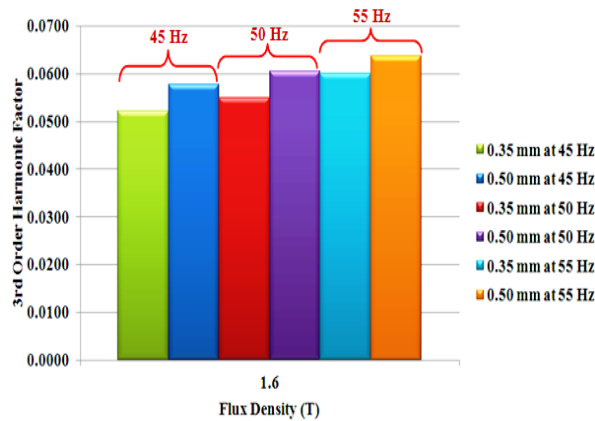

Figure 13. The bars graph of the 3rd harmonic factor versus flux density (1.6 T) at different frequency for both thicknesses.

Figure 13 shows the graph bars of 3rd Harmonic Factor versus Flux Density (1.6 T) for both thicknesses at 45 Hz, 50 Hz and 55 Hz. From figure 13, at 1.6 T with 45 Hz, 50 Hz and 55 Hz for both lamination thickness, the 0.35 mm 3rd harmonic factor is lower than 0.50 mm lamination thickness as shown in table 4. It is due to higher loss can increase the harmonics of material.

Table 4. The 3rd harmonic factor versus flux density (1.6 T) at different frequency.

	0.35 mm (%)	0.50 mm (%)	Diff. (%)
45 Hz	5.22	5.77	9.53
50 Hz	5.49	6.05	9.27
55 Hz	6.01	6.37	5.65

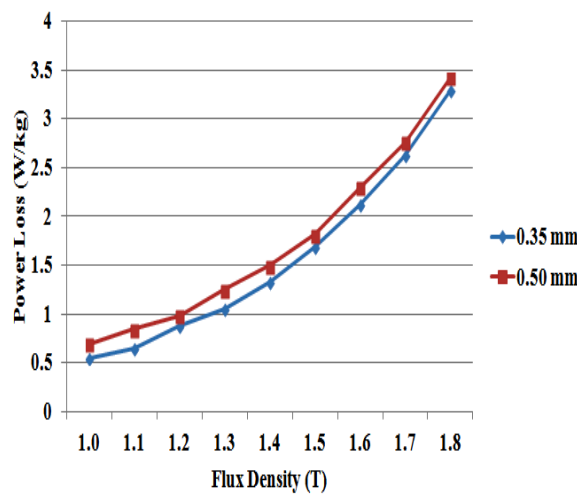

Figure 14. The power loss (W/kg) versus flux density (T) at 50 Hz for both thicknesses.

Figure 14 shows the line graph of the power loss (W/kg) for both lamination thickness with different flux density (T) at 50 Hz. It can be seen that the loss of power between two different thickness is clearly apparent. At 1.5T, the nominal loss of 0.35 mm and 0.50 mm thickness was found which are 1.6886 W/Kg and 1.8108 W/Kg thru the Epstein test, correspondingly. The ratio difference between 2 lamination thicknesses is 6.75 % and it prove that the 0.35 mm has lower power loss compared to 0.50 mm lamination thickness.

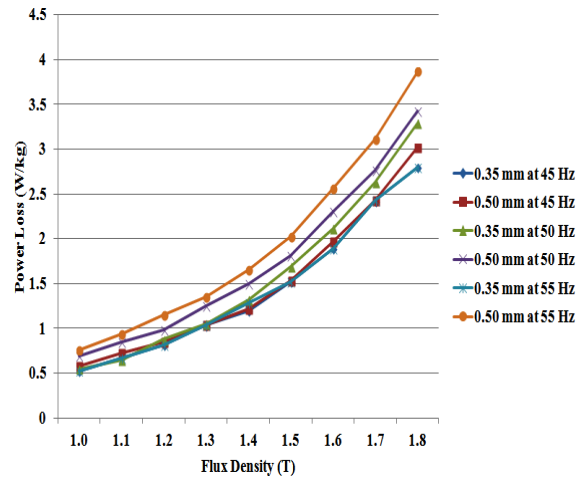

Figure 15. The line graph of power loss (W/kg) versus flux density (T) for 0.35 mm & 0.50 mm at different frequency.

Figure 15 shows the graph line of power loss (W/kg) versus flux density (T) for both thickness at 40 Hz, 50 Hz and 55 Hz. Regarding to the figure 15, the loss of power for both lamination thickness clearly visible. The nominal power loss at 1.5 T for both thicknesses with different frequency thru Epstein test approach are shown in table 5 and it prove that the 0.35 mm shows decrease the power loss compared to 0.50 mm lamination thickness.

Table 5. Power loss (W/kg) versus flux density (T) for 0.35 mm & 0.50 mm at different frequency using Epstein test.

	0.35 mm (%)	0.50 mm (%)	Diff. (%)
45 Hz	1.5215	1.5324	0.71
50 Hz	1.6886	1.8108	6.75
55 Hz	1.5215	2.0228	24.8

4. Conclusion

The power loss, flux leakage at corner, flux leakage at limb and harmonic factor for 0.35 mm is lower compared to the 0.50 mm lamination thickness of steel sheet. From this observation, it proves that the 0.35 mm show decreasing in losses of power compared to 0.50 mm lamination thickness of steel sheets.

Acknowledgement

The authors wish to thank the Director and members of Renewable Energy Research Laboratory (RENERAL), Electrical Engineering Section, British Malaysian Institute, Universiti Kuala Lumpur, for the technical and financial support.

References

- [1] M R Mohyin, M I Daut and N A M Kajaan 2010 *2010 4th International Power Engineering and Optimization Conference (PEOCO)* IEEE pp. 545-548
- [2] Y Yanawati, A Norjasmi, M Syatirah, S N Shafiqin, I Pungut, N Baharudin and B Azuddin 2013 *2013 IEEE 7th International Power Engineering and Optimization Conference (PEOCO)* IEEE pp. 600-602
- [3] A J Clerc and A Muetze 2012 *IEEE Trans. Ind. Appl.* **48** 1344-1352
- [4] M F Rodrigues, M A da Cunha, S da Costa Paolinelli and A B Cota 2013 *J. Magn. Magn.* **331** 24-27
- [5] H-Z Li, H-T Liu, Z-Y Liu, H-H Lu, H-Y Song and G-D Wang 2014 *Mater. Charact.* **88** 1-6
- [6] G Zu, X Zhang, J Zhao, Y Cui, Y Wang and Z Jiang 2015 *Mater. Des.* **85** 455-460
- [7] Y B Yahya, M K Rahmat, S F Salleh and T A R T Abdullah 2019 *Int. J. Integr. Eng.* **11** 14-19
- [8] P Beckley 2002 IET
- [9] C Hubert *Electrical Machines*, 2002, Prentice-Hall Publishing Company, Upper Saddle River, NJ