



UNIVERSITI KUALA LUMPUR
Malaysian Institute of Marine Engineering Technology

FINAL EXAMINATION
JULY 2025 SEMESTER SESSION

SUBJECT CODE : LMB32202

SUBJECT TITLE : MARINE CONTROL SYSTEM

PROGRAMME NAME : BACHELOR OF MARINE ENGINEERING
(FOR MPU: PROGRAMME LEVEL) TECHNOLOGY WITH HONOURS

TIME / DURATION : 09.00 AM - 11.30 AM
(2 HOURS 30 MINUTES)

DATE : 23 DECEMBER 2025

INSTRUCTIONS TO CANDIDATES

1. Please read **CAREFULLY** the instructions given in the question paper.
2. This question paper has information printed on both sides of the paper.
3. This question paper consists of **TWO (2)** sections; Section A and Section B.
4. Answer **ALL** questions in Section A. For Section, answer **THREE (3)** questions **ONLY**.
5. Please write your answers on this answer booklet provided.
6. Answer **ALL** questions in English language **ONLY**.
7. Answer should be written in blue or black ink except for sketching, graphic and illustration.

THERE ARE 4 PAGES OF QUESTIONS, EXCLUDING THIS PAGE.

INSTRUCTION:

Section A consists of TWO (2), Answer ALL QUESTION (Total: 40 marks)

Please use the answer booklet provided.

Question 1

With reference to the marine control system.

- (a) Determine FOUR (4) requirements to apply for achieving a good control system (4 marks)
- (b) Explain FOUR (4) advantages of automation control. (8 marks)
- (c) Sketch and label FOUR (4) a single and double port globe valve. (8 marks)

Question 2

With reference to hydraulic transmitters of the steering gear control systems.

- (a) Sketch and label FIVE (5) the hydraulic transmitter steering gear control system. (10 marks)
- (b) Explain the application of hydraulic systems in the marine steering gear control and their operation (10 marks)

Section B consists of FOUR (4) QUESTION

Answer THREE (3) QUESTION

(Total: 60 marks)

Question 3

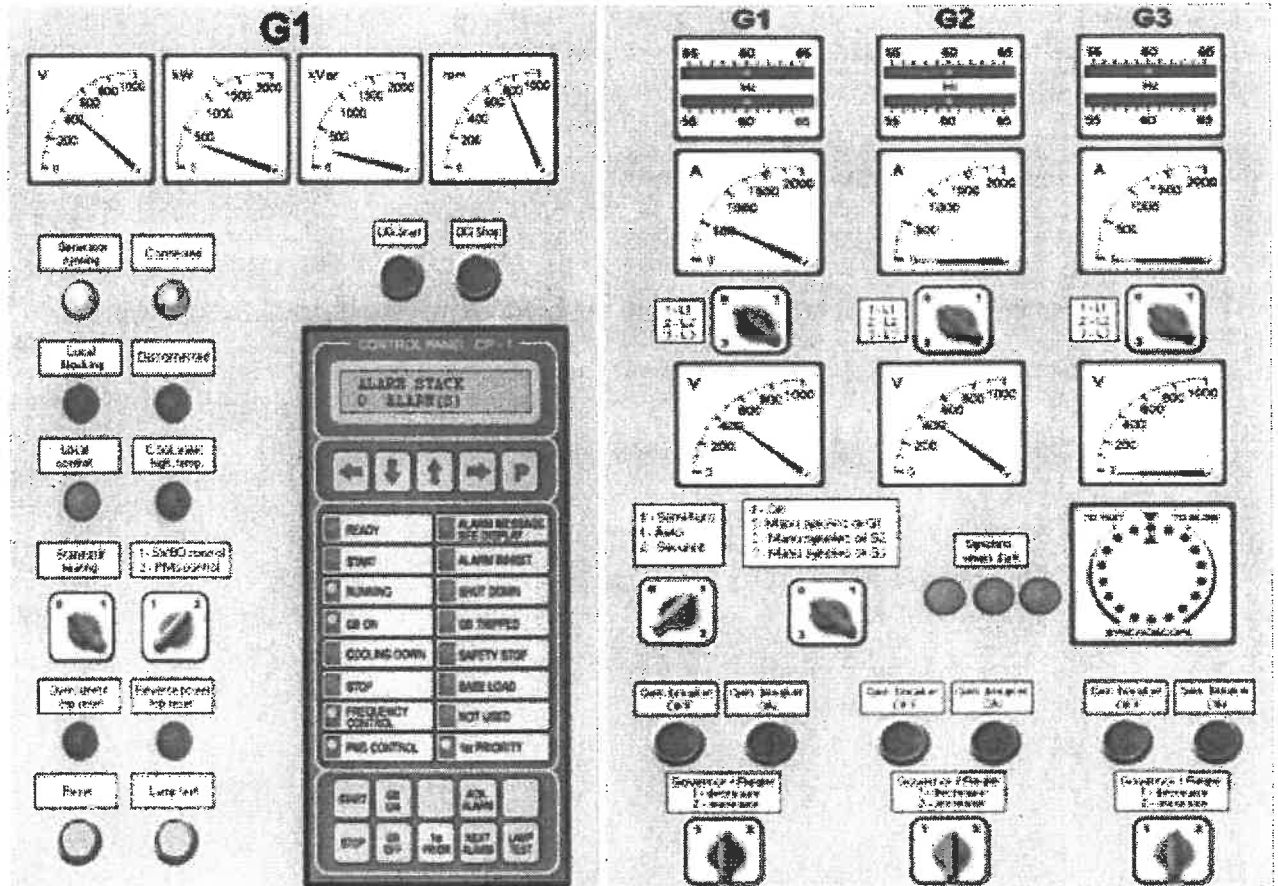

Figure Q3: Generator control Panel and Synchronizing Panel

With reference to shipboard electrical supply power control system shown in Figure Q3:

- (a) Identified generator engine starting mode option process before switching ON the breaker. (6 marks)
- (b) Analyses the causes of synchronise failure between incoming generator with the currently running generator. (14 marks)

Question 4

Pneumatic Manoeuvring System

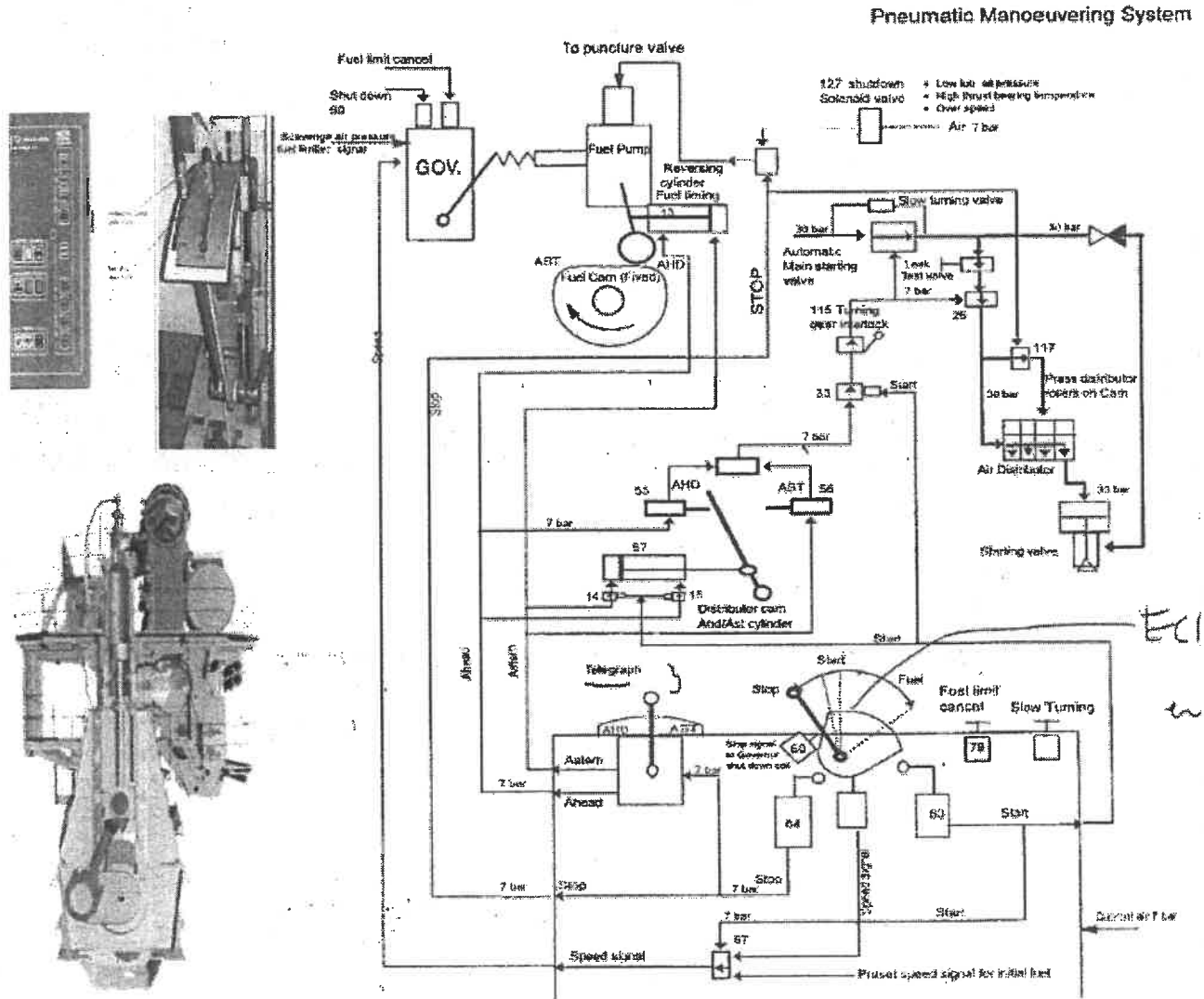

Figure Q4: starting air control system diagram

The engine uses a pneumatically operated starting air control system diagram shown in figure Q4.

- (a) Analyse possible causes for the engine's failure to run, focusing on the control system components and safety interlocks. (12 marks)
- (b) Explain the standard troubleshooting procedure to be applied. (8 marks)

Question 5

With reference to the marine propulsion steam turbine control system.

- (a) Sketch and label FIVE (5) the basic marine propulsion steam turbine control system.

(8 marks)

- (b) Analyse possible causes for the turbine rpm failure to increase, focusing on the control system components and safety interlocks

(12 marks)

Question 6

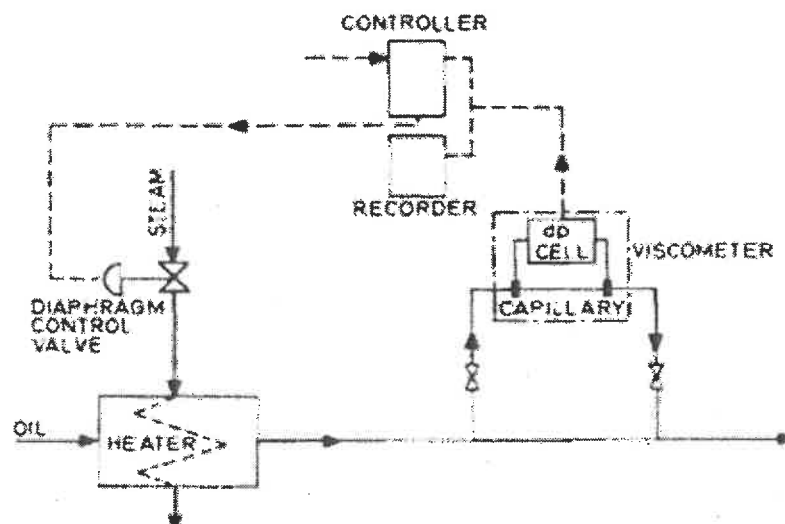

Figure Q6

With referent to the marine diesel engine fuel viscosity monitoring control system in figure Q6.

- (a) Identify FIVE (5) root cause of the fuel viscosity monitoring failure.

(10 marks)

- (b) Explain FIVE (5) corrective actions to resolve the issue and restore the fuel viscosity monitoring system.

(10 marks)

END OF QUESTION