



UNIVERSITI KUALA LUMPUR
Malaysian Institute of Marine Engineering Technology

FINAL EXAMINATION
JULY 2025 SEMESTER SESSION

SUBJECT CODE : LMD13503
SUBJECT TITLE : ENGINEERING SCIENCE
PROGRAMME NAME : DET IN MARINE ENGINEERING
(FOR MPU: PROGRAMME LEVEL)
TIME / DURATION : 09.00 AM - 12.00 PM
(3 HOURS)
DATE : 17 DECEMBER 2025

INSTRUCTIONS TO CANDIDATES

1. Please read **CAREFULLY** the instructions given in the question paper.
 2. This question paper has information printed on both sides of the paper.
 3. This question paper consists of **TWO (2)** sections; Section A and Section B.
 4. Answer **ALL** question in Section A, and **TWO (2)** questions **ONLY** in Section B.
 5. Please write your answers on this answer booklet provided.
 6. Answer **ALL** questions in English language **ONLY**.
 7. Table of formulae and appendices has been appended for your reference.
-

THERE ARE 9 PAGES OF QUESTIONS, EXCLUDING THIS PAGE.

SECTION A (Total: 60 marks)

**INSTRUCTION: Answer ALL questions.
Please use the answer booklet provided.**

Question 1

With reference to linear motion and dynamics:

- (a) i. Differentiate between speed and velocity. (4 marks)
- ii. Explain free fall motion. (4 marks)
- (b) i. Describe work done on an object. (3 marks)
- ii. Distinguish between kinetic energy and potential energy. (4 marks)
- (c) i. Define temperature. (2 marks)
- ii. State THREE (3) methods of heat transfer. (3 marks)

Question 2

With reference to linear motion:

(a) A small supply boat is travelling initially at 5 m/s. The boat is moving with a constant acceleration of 0.8 m/s² in 20 s. Compute:

i. the distance travel by the boat in 20 s. (3 marks)

ii. the speed of the boat at 20 s (3 marks)

iii. the distance in the next 30 s if the boat continues its motion with constant acceleration. (3 marks)

(b) Figure 1 shows a graph of speed versus time to represent the linear movement of a watercraft. Calculate:

i. the acceleration in the first 12 seconds and in the last 5 seconds (4 marks)

ii. total distance travelled by the watercraft (4 marks)

iii. the average speed of the motion. (3 marks)

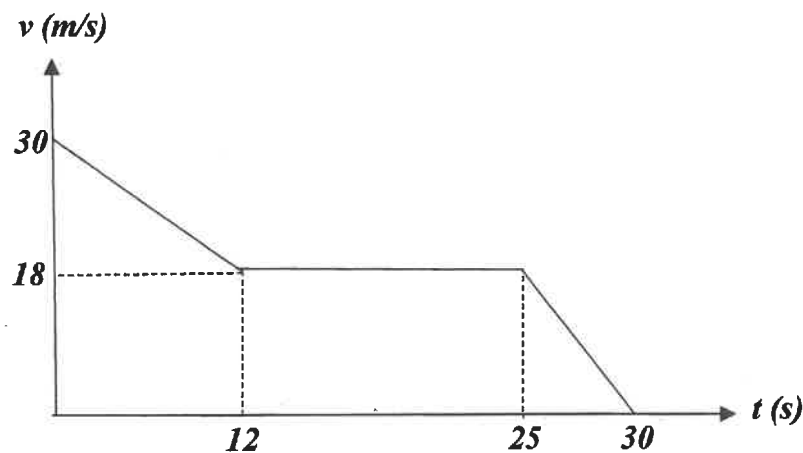

Figure 1

Question 3

With reference to work, energy and power:

(a) A crane is used to lift a 1200 kg engine from the dock to the deck. The hook raised the engine at a speed of 0.5 m/s vertically to a height of 8 m. Calculate:

i. the work done by the crane to change its speed to 2 m/s (4 marks)

ii. the force required move the engine to a height of 8 m. (3 marks)

iii. the power required by the crane to move the engine to a height of 8 m. (6 marks)

(b) Figure 2 shows a 15 kg container slide down from a height of 0.6 m from a conveyor at a speed of 1.2 m/s.

i. Compute the total mechanical energy of the container at point A. (3 marks)

ii. Calculate the speed of the container at point B if the mechanical energy is conserved. (4 marks)

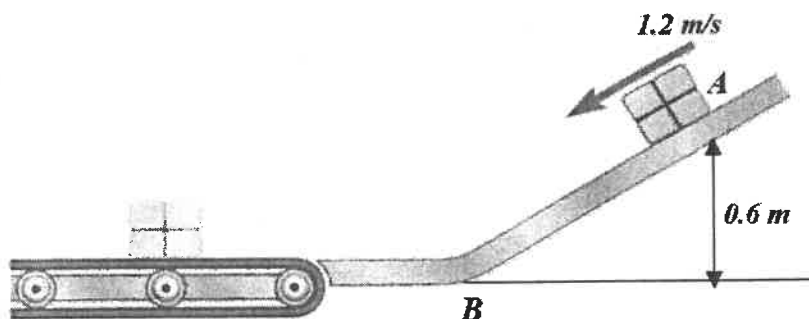

Figure 2

SECTION B (Total: 40 marks)

INSTRUCTION: Answer only TWO (2) questions.

Please use the answer booklet provided.

Question 4

With reference to Newton's Law of Motion:

A box ($m_A = 10 \text{ kg}$) is placed on a rough plane and connected via a string and a pulley to a hanging weight ($m_B = 8 \text{ kg}$). The coefficient of friction between m_A and the plane is 0.15. A force of 100 N is applied so that the system moves in the direction shown in Figure 3.

- (a) Sketch the free body diagram to show all the forces acting on the system. (4 marks)
- (b) Calculate the frictional force that opposes the movement of m_A . (7 marks)
- (c) Determine the acceleration of the system. (9 marks)

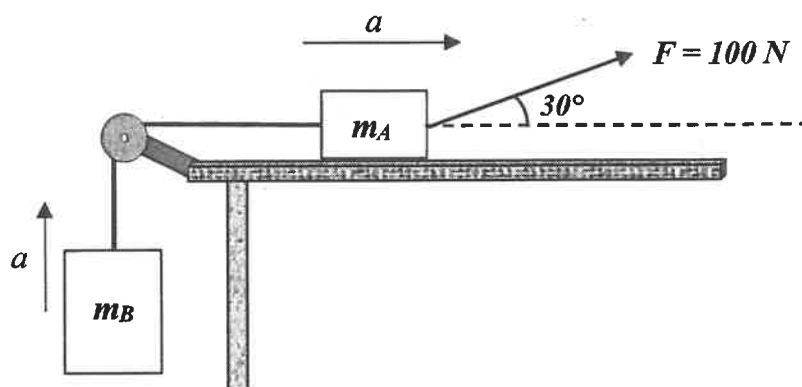

Figure 3

Question 5

With reference to rotational motion and simple harmonic motion:

(a) A flywheel of radius 15 cm rotates at an angular velocity of 40 rev/min. After 30 s, the angular velocity is increased to 200 rev/min. Determine:

i. the angular acceleration made by the wheel in unit rad/s^2 . (5 marks)

ii. the torque acted on the flywheel if the mass of the flywheel is 28 kg. (6 marks)

(b) A load of mass 400 g is attached to the end of a spring so that it is vibrating in Simple Harmonic Motion. The amplitude of the motion is 6 cm and the period of the motion is 0.8 s. Calculate:

i. the angular frequency (3 marks)

ii. the spring constant of the spring (3 marks)

iii. the maximum acceleration of the motion (3 marks)

Question 6

With reference to fluid and heat:

- (a) A mercury manometer is attached to gas tank to measure its pressure as shown in Figure 4. The relative density of the mercury is 13.6. If the local atmospheric pressure is 107 kPa and the pressure of the gas in the tank is 118 kPa, determine the differential height of the mercury in the manometer tube.

(6 marks)

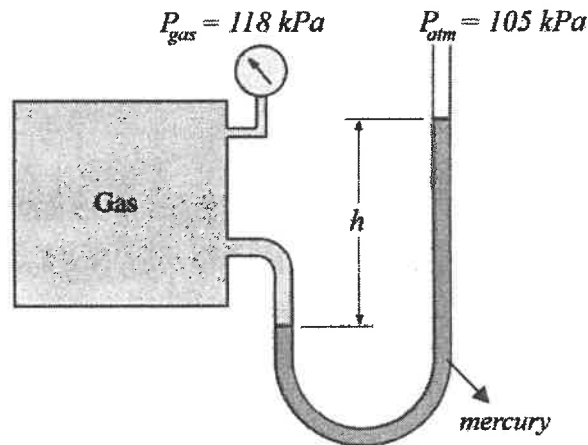

Figure 4

- (b) An engineer is testing the cooling system of a ship's engine. A 5 kg copper block at a temperature of 150°C is placed into a bucket containing 10 kg of water initially at 25°C. The system is well insulated so that there is no heat loss to the surroundings. The copper block and water eventually reach a final equilibrium temperature of 35°C. Given that the specific heat capacity of water is 4200 J/kg.°C. Determine:

i. the heat gained by water

(3 marks)

ii. the specific heat capacity of the copper block.

(3 marks)

(c) In an engine room, a brass rod is welded end-to-end with a steel rod to transfer heat from a hot exhaust manifold to a cooling plate. The brass rod is 0.3 m long with a cross-sectional area of 1.5 cm^2 and a thermal conductivity of $109 \text{ J/s.m.}^\circ\text{C}$. The steel rod is 0.5 m long with the same cross-sectional area and a thermal conductivity of $45 \text{ J/s.m.}^\circ\text{C}$. The hot end of the brass rod is maintained at 200°C and the cold end of the steel rod is maintained at 50°C as shown in Figure 5. Assume steady-state heat conduction and no heat loss to surroundings.

- i. Calculate the temperature at the interface between brass and steel. (4 marks)
- ii. Determine the rate of heat transfer through this combination. (4 marks)

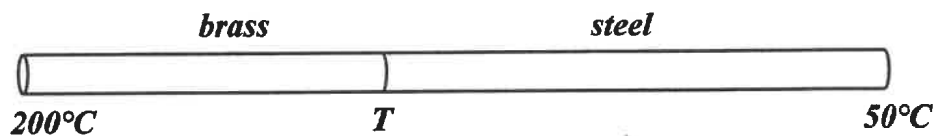

Figure 5

END OF EXAMINATION PAPER

APPENDIX

1. TABLE OF FORMULAE

$v = u + at$	$s = ut + \frac{1}{2} at^2$	$s = \frac{1}{2}(u + v)t$
$v^2 = u^2 + 2as$	$W = F \cos \theta . x$	$W = KE_f - KE_i$
$KE = \frac{1}{2}mv^2$	$PE = mgh$	$P = \frac{W}{t}$
$W = mg$	$F = ma$	$F_f = \mu F_N$
$\omega_f = \omega_i + \alpha t$	$\theta = \frac{1}{2}(\omega_i + \omega_f)t$	$\theta = \omega_i t + \frac{1}{2} \alpha t^2$
$\omega_f^2 = \omega_i^2 + 2\alpha\theta$	$f = \frac{1}{T}$	$\omega = 2\pi f$
$\tau = I\alpha$	$\omega = \sqrt{\frac{k}{m}}$	$a = -\omega^2 x$
$v = \omega\sqrt{A^2 - x^2}$	$RD = \frac{\rho_{\text{substance}}}{\rho_{\text{water}}}$	$P = \rho gh$
$\rho = \frac{m}{V}$	$Q = mc\Delta T$	$\frac{Q}{t} = \frac{kA\Delta T}{l}$

2. CONSTANT VALUES:

Gravitational acceleration, $g = 9.81 \text{ m/s}^2$

Density water = 1000 kg/m^3

Standard atmospheric pressure = $1 \text{ atm} = 101.3 \text{ kPa}$

3. MOMENT OF INERTIA OF HOMOGENEOUS RIGID OBJECT

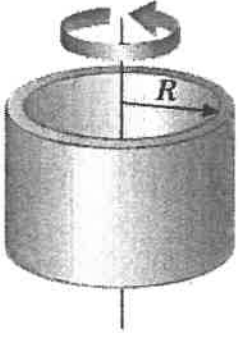
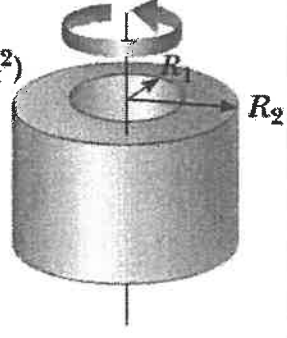
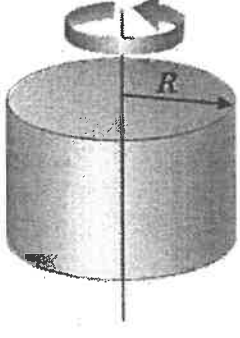
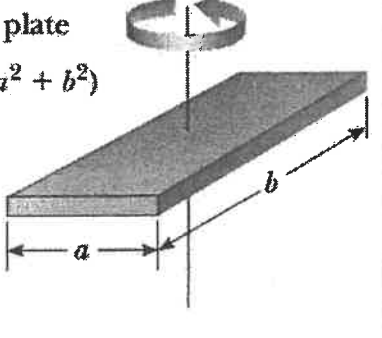
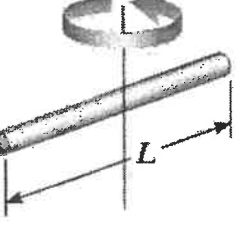
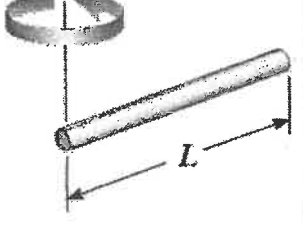
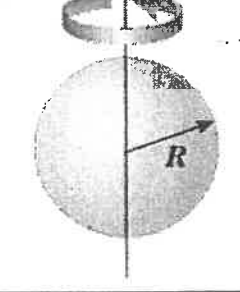
<p>Hoop or thin cylindrical shell $I_{CM} = MR^2$</p>		<p>Hollow cylinder $I_{CM} = \frac{1}{2} M(R_1^2 + R_2^2)$</p>	
<p>Solid cylinder or disk $I_{CM} = \frac{1}{2} MR^2$</p>		<p>Rectangular plate $I_{CM} = \frac{1}{12} M(a^2 + b^2)$</p>	
<p>Long, thin rod with rotation axis through center $I_{CM} = \frac{1}{12} ML^2$</p>		<p>Long, thin rod with rotation axis through end $I = \frac{1}{3} ML^2$</p>	
<p>Solid sphere $I_{CM} = \frac{2}{5} MR^2$</p>		<p>Thin spherical shell $I_{CM} = \frac{2}{3} MR^2$</p>	