



UNIVERSITI KUALA LUMPUR
Malaysian Institute of Marine Engineering Technology

FINAL EXAMINATION
JULY 2025 SEMESTER SESSION

SUBJECT CODE	: LED22803
SUBJECT TITLE	: MARINE INSTRUMENTATION AND CONTROL
PROGRAMME NAME <small>(FOR MPU: PROGRAMME LEVEL)</small>	: DIPLOMA OF ENGINEERING TECHNOLOGY IN ELECTRICAL AND ELECTRONICS (MARINE)
TIME / DURATION	: 09.00 AM - 11.30 AM (2 HOURS 30 MINUTES)
DATE	: 19 DECEMBER 2025

INSTRUCTIONS TO CANDIDATES

1. Please read **CAREFULLY** the instructions given in the question paper.
2. This question paper has information printed on both sides of the paper.
3. This question paper consists of **TWO (2)** sections; Section A and Section B.
4. Answer **ALL** question in Section A, and **TWO (2)** questions in Section B.
5. Please write your answers on this answer booklet provided.
6. Answer **ALL** questions in English language **ONLY**.

THERE ARE 6 PAGES OF QUESTIONS, EXCLUDING THIS PAGE.

SECTION A (Total: 60 marks)

INSTRUCTION: Answer all questions.

Please use the answer booklet provided.

Question 1

With reference to the introduction to measurement and instrumentation:

- (a) State TWO (2) primary functions of an instrument. (4 marks)
- (b) Identify the definitions of accuracy and precision in measurement. (4 marks)
- (c) Define the term "sensor" as used in measurement and control systems. (4 marks)
- (d) Identify TWO (2) parameters that can be measured using long-distance analogue measuring lines in a ship's monitoring system. (4 marks)
- (e) "This type of error is primarily caused by human mistakes during instrument reading, usage, or when recording observations. It may also result from incorrect instrument adjustments or computational errors. Such errors cannot be analyzed mathematically, and while they cannot be completely eliminated, they can be reduced."
- i. State the name of this error. (2 marks)
- ii. List of TWO (2) methods to minimize this error. (2 marks)

Question 2

With reference to transducers/ sensors technology:

- (a) Define the term sensor, actuator, and transducer. (3 marks)
- (b) State THREE (3) rules a good sensor shall obey. (3 marks)
- (c) List FOUR (4) main types of sensors and ONE (1) example for each type. (8 marks)
- (d) Describe THREE (3) applications or functions of pressure sensors used on board ships. (6 marks)

Question 3

With reference to electrical and electronic measuring instruments:

(a) Figure 1 shows a basic circuit of a slide wire potentiometer.

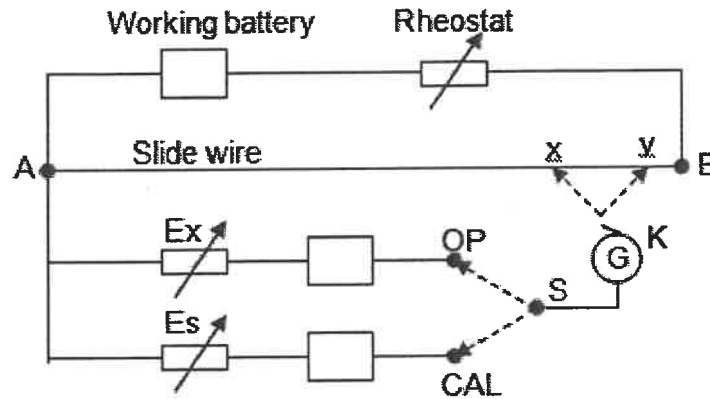

Figure 1

- i. State THREE (3) functions of a potentiometer. (3 marks)

- ii. Describe the operating principles of a Basic Slide-Wire Potentiometer. (5 marks)

With reference to signal conditioning:

- (b) List SIX (6) main functions of signal conditioning. (6 marks)

- (c) Describe THREE (3) differences between the DC and AC Bridges. (6 marks)

SECTION B (Total: 40 marks)

INSTRUCTION: Answer TWO (2) questions only.

Please use the answer booklet provided.

Question 4

With reference to the introduction to measurement and instrumentation:

- a) Explain TWO (2) basic concepts of qualities of measurement. (5 marks)
- b) Explain TWO (2) common types of errors in measurement. (5 marks)
- c) Explain TWO (2) main characteristics of instrumentation. (5 marks)
- d) Explain the measuring instruments used in electrical systems. (5 marks)

Question 5

With reference to Oxygen and Other Gases Detection Systems:

(a) Explain an oxygen sensor and main function on board a ship.
(5 marks)

(b) Explain the properties and the characteristics of an oxygen detection system.
(5 marks)

(c) Explain the applications of oxygen or other gas detection systems on board ships.
(5 marks)

(d) Explain THREE (3) main characteristics of an oxygen detection system.
(5 marks)

Question 6

With reference to Fire and Alarm Detection System:

- (a) Explain the main purpose of a fire alarm detection system on board a ship?
(5 marks)

- (b) Explain TWO (2) examples of initiating devices and ONE (1) example of a notification appliance.
(5 marks)

- (c) Explain the functions of an emergency voice alarm communication system.
(5 marks)

- (d) Explain the principle of operation of a photoelectric oil detection system.
(5 marks)

END OF EXAMINATION PAPER