



**UNIVERSITI KUALA LUMPUR
Malaysia France Institute**

**FINAL EXAMINATION
SEPTEMBER 2013 SESSION**

SUBJECT CODE : FMD10202
SUBJECT TITLE : DYNAMICS
LEVEL : DIPLOMA
TIME / DURATION : 2.5 HOURS
DATE :

INSTRUCTIONS TO CANDIDATES

1. Please read the instructions given in the question paper **CAREFULLY**.
 2. This question paper is printed on both sides of the paper.
 3. Please write your answers on the answer booklet provided.
 4. Answer should be written in blue or black ink except for sketching, graphic and illustration.
 5. This question paper consists of **TWO (2)** sections. Section A and B. Answer **ALL** questions in Section A. For Section B, answer **TWO (2)** questions only.
 6. Answer all questions in English.
-

THERE ARE 5 PAGES OF QUESTIONS, EXCLUDING THIS PAGE.

SECTION A (Total: 60 marks)

INSTRUCTION: Answer ALL questions.
Please use the answer booklet provided.

Question 1

A student finds a rock on the way to school. In the laboratory, he determines that the volume of the rock is 22.70 cm^3 , and the mass is 39.94 g . From this data, calculate the density in kilograms per cubic meter and relative density of the rock.

(10 marks)

Question 2

The plate is subjected to the forces acting on members *A* and *B* as shown in *Figure 1*. Determine the magnitude of the resultant of these forces and its direction measured clockwise from the positive *x* axis.

(10 marks)

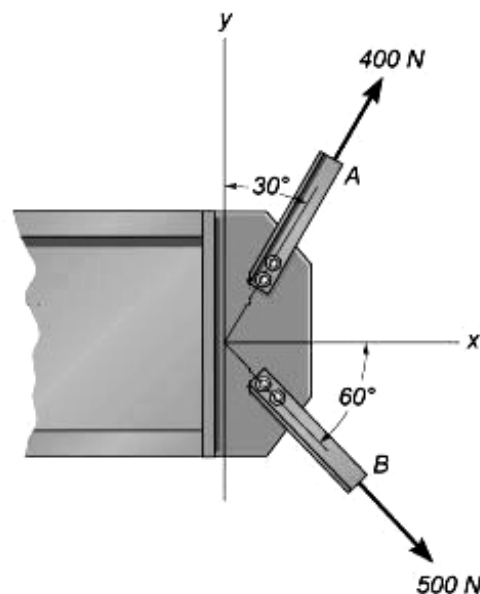

Figure 1

Question 3

In *Figure 2*, determine the resultant moment of the forces about point A.

(10 marks)

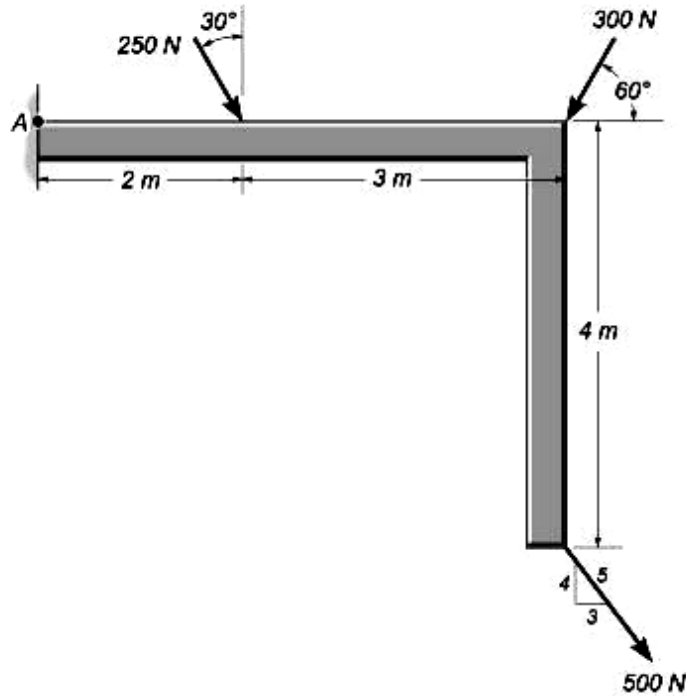

Figure 2

Question 4

The 400 kg mine car as shown in *Figure 3* is hoisted up the incline at 36° to the horizontal. If the force in the cable is 2800 N, determine the acceleration of the car. All resistance is neglected.

(10 marks)



Figure 3

Question 5

A rotor of a steam turbine revolving at 2500 rpm slows down to 600 rpm in 30 s after steam supply has been adjusted. Determine the angular deceleration, and the number of revolutions made by the rotor in that time.

(10 marks)

Question 6

An electrically powered train car draws 40 kW of power. If the car has weight 280 kN and starts from rest, determine the maximum speed it attains in 50 s. The mechanical efficiency is 0.75.

(10 marks)

SECTION B (Total: 40 marks)

INSTRUCTION: Answer TWO (2) questions only.

Please use the answer booklet provided.

Question 7

Determine the magnitude and angle θ of F so that the particle is in equilibrium as shown in *Figure 4* below.

(20 marks)

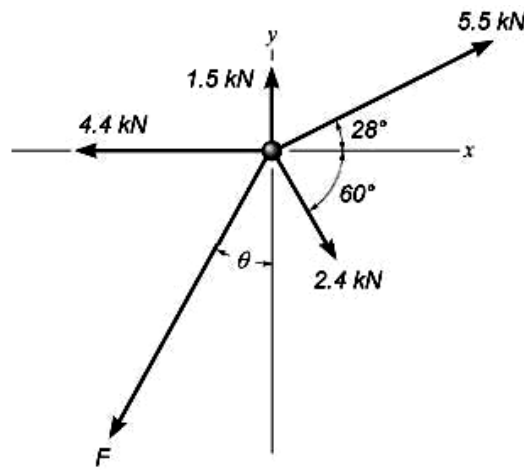

Figure 4

Question 8

Determine the coordinates of the centroid of the shaded area in *Figure 5*. All dimensions are in millimeters.

(20 marks)

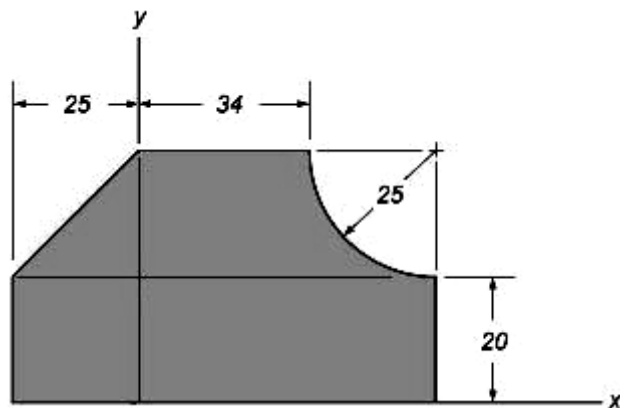

Figure 5

Question 9

The projectile as shown in *Figure 6* reaches its maximum elevation at point A. Determine the initial velocity, V_0 and angle θ . Calculate also total time from point 0 to B.

(20 marks)

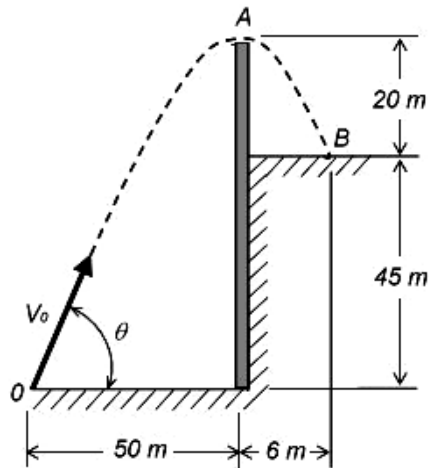

Figure 6

Question 10

In *Figure 7*, a 50 kg crate is pushed down an inclined plane, at 15° to the horizontal, by a force of 450 N. The coefficient of friction is 0.35. Using the work-energy method, determine the distance measured along the plane in which the velocity will change from 3.6 km/h to 18 km/h.

(20 marks)

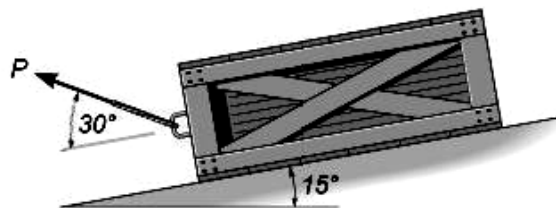

Figure 7

END OF QUESTION