



**UNIVERSITI KUALA LUMPUR**  
**Malaysia France Institute**

---

**FINAL EXAMINATION**  
**JULY 2010 SESSION**

---

**SUBJECT CODE** : FEB 20202  
**SUBJECT TITLE** : MOTOR STARTER AND DRIVES  
**LEVEL** : BACHELOR  
**TIME / DURATION** : 12.30 pm – 2.30 pm  
(2 HOURS)  
**DATE** : 15 NOVEMBER 2010

---

**INSTRUCTIONS TO CANDIDATES**

---

1. Please read the instructions given in the question paper CAREFULLY.
  2. This question paper is printed on both sides of the paper.
  3. Please write your answers on the answer booklet provided.
  4. Answer should be written in blue or black ink except for sketching, graphic and illustration.
  5. This question paper consists of TWO (2) sections. Section A and B. Answer all questions in Section A. For Section B, answer two (2) question only.
  6. Answer all questions in English.
  7. Do not open the question paper until instructed to do so.
- 

THERE ARE 6 PAGES OF QUESTIONS AND 1 PAGE OF APPENDIXES, EXCLUDING THIS PAGE.

---

Question 3

- (a) Figure 4 shows power diagram of a system consists of three induction motors. Calculate the maximum current allowable for:
- i. Motor 1 conductor, Motor 2 conductors, Motor 3 conductors. (6 marks)
  - ii. Thermal Overload Relay F1, F2 and F3 (4 marks)
  - iii. Fuse f4 and f5. (3 marks)
  - iv. Main feeder (Line current) (3 marks)

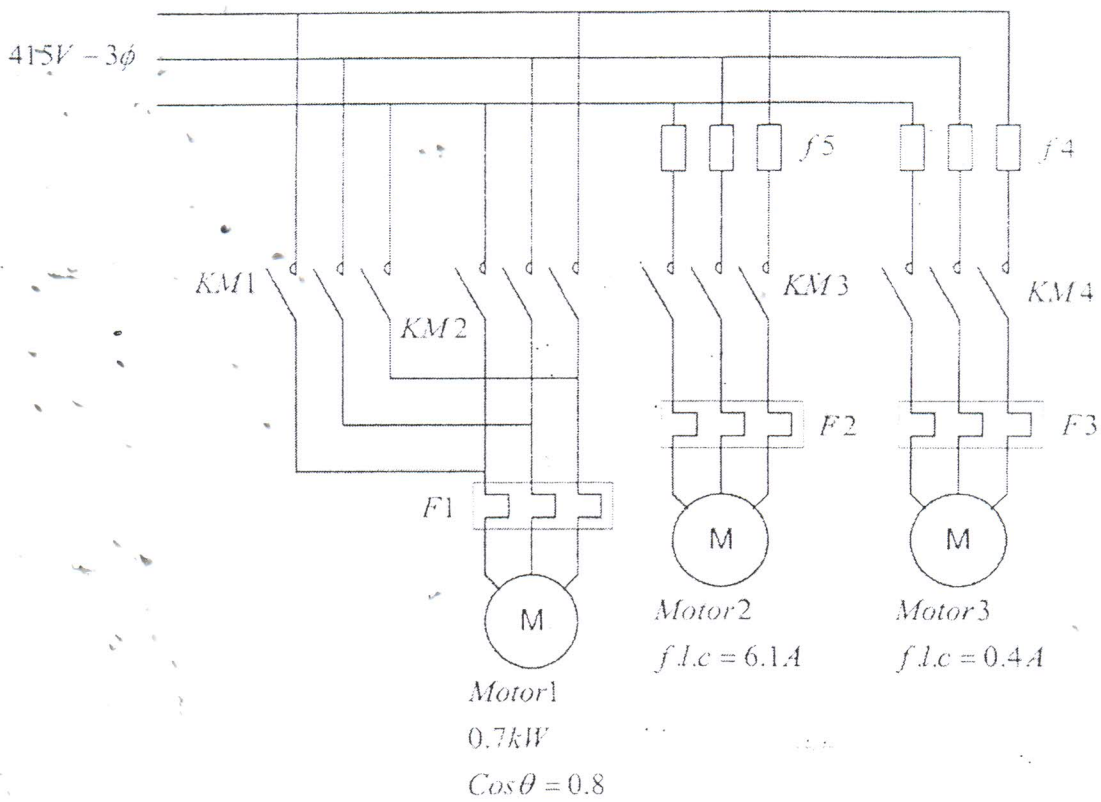

Figure 4: Power diagram

## SECTION B (Total: 60 marks)

INSTRUCTION: Answer only TWO (2) questions.

Please use the answer booklet provided.

## Question 4

- (a) Explain the starting sequence (the principle operation) of the Star-Delta Starting Method.

(8 Marks)

- (b) Draw the characteristics graph of current versus speed for Star-Delta starting method.

(2 Marks)

- (c) The relation between starting torque,  $T_{st}$  and full load torque,  $T_f$  for Star-Delta starting method is as follow:

$$T_{st} \propto I_{st}^2 \text{ and } T_f \propto \frac{I_f^2}{s_f}$$

Prove that:

$$\frac{T_{st}}{T_f} = \frac{1}{3} \left( \frac{I_{sc}}{I_f} \right)^2 s_f$$

(8 Marks)

- (d) A three phase induction motor is tested using a star-delta and auto-transformer starting. The short-circuit current of the motor at normal voltage is seven (7) times full load current and the slip is 4%. Calculate approximately the starting torque in terms of full-load torque when started by (neglect the magnetizing current);

- i. A star-delta starting

(6 marks)

- ii. An auto-transformer with 65% tapping

(6 marks)

Question 5

(a) In the mechanism as shown in Figure 5, motor drives a winch drum through a reduction gear with a gear tooth ratio 0.1. The friction torque at winch shaft is 15 Nm and at motor shaft 10 Nm. Motor speed is 1500 rpm. If the gears have an efficiency of 90%, calculate;

- i. the equivalent moment of inertia of the drive referred to the shaft
- ii. the motor torque

(15 marks)

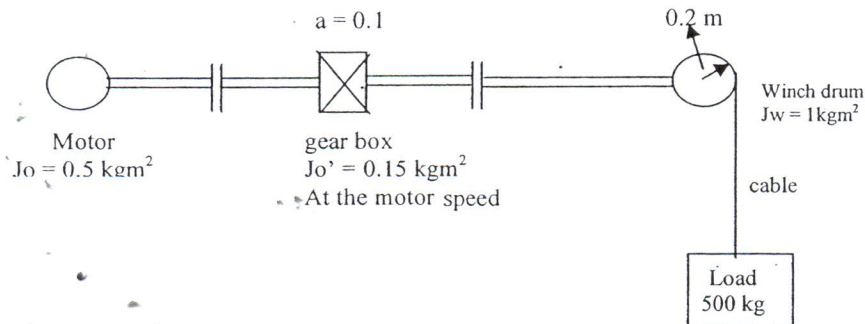

Figure 5

(b) A motor drives two loads, where one has a rotational motion. It is coupled to the motor through a reduction gear with  $a = 0.1$  and efficiency of 90 %. The load has a moment of inertia of  $10 \text{ kgm}^2$  and a torque of 10 Nm. The other loads has translational motion and consists of 1000 kg weight to be lift up at an uniform speed of 1.5 m/s. Coupling between this load and the motor has an efficiency of 85 %. The motor has inertia of  $0.2 \text{ kgm}^2$  and runs at a constant speed of 1420 rpm. Determine:

- i. The equivalent inertia referred to the motor shaft.
- ii. The torque developed by the motor.

(15 marks)

**Question 6**

(a) List three (3) types of errors that will cause the failure to variable speed drives (VSD). (3 marks)

(b) List two (2) stopping methods of variable speed drives (VSD) (2 marks)

(c) A drive has the following parameters:

- $J = 10 \text{ kgm}^2$
- $T = 100 - 0.1N.Nm$ , passive load torque.
- $T_t = 0.05N Nm$ , where  $N$  is the speed in rpm.

Initially the drive is operating in steady-state. Now it is to be reversed. For this motor characteristic is changed to  $T = -100 - 0.1N Nm$ . Calculate:

- i. The steady-state speed
- ii. The steady-state after reversal

(8 marks)

(d) A production system consists of four loads. All the loads being driven by a motor, two have rotational motion and others two with translation motion. Moment of inertia of the motor is  $1.2 \text{ kgm}^2$  and motor runs at a speed of 1000 rpm. Table 1 shows the detail of the loads. Assuming the negligible loss in the transmission, calculate;

- i. The equivalent inertia.
- ii. Torque of the system referred to the motor shaft.

(17 marks)

Table 1

Load	Type of motion	Speed	Inertia/Mass	Torque/Force
A	Rotational	200 rpm	$7 \text{ kgm}^2$	10 Nm
B	Rotational	200 rpm	$5 \text{ kgm}^2$	6 Nm
C	Translational	10 m/S	10 kg	20 N
D	Translational	10 m/S	20 kg	30 N

**END OF QUESTION PAPER**

## APPENDIX

Useful formula:

Motor torque;

$$T = T_{\ell} + J \frac{d\omega_m}{dt}$$

Moment of inertia;

$$J = J_0 + a_1^2 J_1$$

$$J = J_0 + M_1 \left( \frac{V_1}{\omega_m} \right)^2$$

Load torque;

$$T_{\ell} = T_{\ell 0} + \frac{a_1 T_{\ell 1}}{\eta_1}$$

$$T_{\ell} = T_{\ell 0} + \frac{F_1}{\eta_1} \left( \frac{v_1}{\omega_m} \right)$$

Time taken for drive speed to change from  $\omega_{m1}$  to  $\omega_{m2}$

$$t = J \int_{\omega_{m1}}^{\omega_{m2}} \frac{d\omega_m}{T(\omega_m) - T_{\ell}(\omega_m)}$$

Moment inertia of flywheel

$$J = \frac{T_r}{(\omega_{m0} - \omega_{mr})} \left[ \frac{t_h}{\log_e \left( \frac{T_{\ell h} - T_{\min}}{T_{\ell h} - T_{\max}} \right)} \right]$$