

Analysing generator matrices G of similar state but varying minimum determinants

This content has been downloaded from IOPscience. Please scroll down to see the full text.

2016 IOP Conf. Ser.: Mater. Sci. Eng. 152 012067

(<http://iopscience.iop.org/1757-899X/152/1/012067>)

View [the table of contents for this issue](#), or go to the [journal homepage](#) for more

Download details:

IP Address: 111.221.54.117

This content was downloaded on 27/01/2017 at 06:56

Please note that [terms and conditions apply](#).

You may also be interested in:

[Performance of LDPC codes over symmetric channels](#)

Toshiyuki Tanaka and David Saad

[Defect-tolerant interconnect to nanoelectronic circuits](#)

Philip J Kuekes, Warren Robinett, Gadiel Seroussi et al.

[Improved voltage margins using linear error-correcting codes in resistor-logic demultiplexers for nanoelectronics](#)

Philip J Kuekes, Warren Robinett and R Stanley Williams

Analysing generator matrices \mathbf{G} of similar state but varying minimum determinants

H Harun^{1,2*}, M F Razali^{1,2} and N A Abdul Rahman²

¹Avionics Section, UniKL MIAT, Malaysia

²Aerospace Engineering Department, Universiti Putra Malaysia, Malaysia

*harlisya@unikl.edu.my

Abstract. Since Tarokh discovered Space-Time Trellis Code (STTC) in 1998, a considerable effort has been done to improve the performance of the original STTC. One way of achieving enhancement is by focusing on the generator matrix \mathbf{G} , which represents the encoder structure for STTC. Until now, researchers have only concentrated on STTCs of different states in analyzing the performance of generator matrix \mathbf{G} . No effort has been made on different generator matrices \mathbf{G} of similar state. The reason being, it is difficult to produce a wide variety of generator matrices \mathbf{G} with diverse minimum determinants. In this paper a number of generator matrices \mathbf{G} with minimum determinant of four (4), eight (8) and sixteen (16) of the same state (i.e., 4-PSK) have been successfully produced. The performance of different generator matrices \mathbf{G} in term of their bit error rate and signal-to-noise ratio for a Rayleigh fading environment are compared and evaluated. It is found from the MATLAB simulation that at low SNR (<8), the BER of generator matrices \mathbf{G} with smaller minimum determinant is comparatively lower than those of higher minimum determinant. However, at high SNR (>14) there is no significant difference between the BER of these generator matrices \mathbf{G} .

1. Introduction

The rapid growth of data usage, as well as information and communications technology services, has forged in increasing the information capacity. Hitherto, a reliable high-speed wireless communication channels is imperative for reliable transmission without increasing the transmitted power or sacrificing the bandwidth [1, 2]. A great deal of research has been carried out to improve wireless communication transmission [3-7] since the transmitted signals in wireless environment are received through multiple paths where they are attenuated by fading phenomenon as well as interference from other applications that are sharing the same transmission medium. These situations result in performance degradations. The increase in demand for data intensive applications has also created a need for high transmission data rate, spectral efficiency and also transmission reliability. Data rate describes how fast data can be transmitted, whilst spectral efficiency is indicated by the data rate over a certain frequency band. The transmission reliability, on the other hand, is measured by the probability that the transmitted data can be correctly detected. Diversity techniques are broadly applied to increase the information capacity as well as to decrease the effects of multiple path fading.

The diversity techniques can be divided into time, frequency and space diversity. These techniques require replicas of transmitted signal, which uncorrelated or independent to each other at the receiving terminal. The main foundation of the diversity technique is that, if two or more independent signals are received, they will fade in an uncorrelated way such that some signals are severely attenuated whilst the others will be less attenuated. The proper combination of the transmitted signals' replicas at the



receiver will greatly scale down the fading by increasing overall received signal-to-noise ratio (SNR), thus improving the reliability of the transmissions [1, 2, 8, 9]. In space diversity or so-called antenna diversity technique, antenna arrays are arranged in space in proper distance to obtain the uncorrelated signals to mitigate loss in bandwidth efficiency. Space diversity is generally classified into “Transmit Diversity” and “Receive Diversity”. Transmit diversity is more practical than receive diversity for enhancing the downlink (i.e. bottleneck in broadband asymmetric applications like internet browsing and downloading) to preserve the small size and low power consumption features of the user terminal. It is more practical to consider transmit diversity for the downlink (i.e. from base stations to mobile) communication because it is easy to install multiple transmit antennas at the base station, as well as providing them the extra power for multiple transmissions.

The space-time coding was first introduced by Tarokh *et al.* [8, 9] in 1998 as a novel approach for providing transmit diversity for multiple-antenna fading channel. Space-Time Trellis Codes (STTCs) is one of the coding structures in the space-time coding technique that can be utilised to improve the performance of the wireless communication systems over fading channels. STTC has been proven to efficiently utilise transmit diversity and effectively exploit the effects of multipath fading to increase the information capacity of the multiple antenna systems [8-10]. STTCs rely on transmitting multiple, redundant copies of a data stream to the receiver in the hope that at least some of them will survive the physical path between transmission and reception in a good state to allow reliable decoding. STTCs combat the effects of fading, hence achieving high spectral efficiencies and performance (capacity) gains [8-10]. STTCs are based on the trellis structure in which its encoding architecture relies on the generator matrix \mathbf{G} . Thus, all possible combinations of the coefficients in the generator matrix \mathbf{G} is imperative in the STTC design so that resultant STTCs are capable of optimising both diversity and coding gains. This implies that, the quality of the transmission of STTC communication system depends on the generator matrix \mathbf{G} . From its early introduction in 1998 [9] until recently, techniques in evaluating generator matrix \mathbf{G} by performing a full code search on the coefficients on the generator matrix \mathbf{G} have been developed and improved [3-5, 7, 11-15, 18]. Mostly, the interest is on the different states, to evaluate the overall STTC performance. Realising the importance in analysing the behaviour of different generator matrices within the same state in improving the performance of STTC, a few generator matrices \mathbf{G} with different minimum determinant has been produced in this paper. Thorough analyses on the impact of bit error rate (BER) and SNR towards different generator matrix \mathbf{G} with different minimum determinants within the same state have also been explored in this paper.

2. STTC design criteria

The design of optimal STTC is based on rank and determinant criterion (RDC). Tarokh's contribution in designing optimal STTCs in quasi-static flat Rayleigh fading channels is determined by matrices constructed from pairs of distinct code sequences [9]. The minimum rank (rank criterion) among these matrices quantifies the diversity gain while the minimum determinant (determinant criterion) of these matrices quantifies the coding gain. RDC is developed by Tarokh to minimise the pairwise error probability (PEP). The pairwise error probability (PEP), denoted as $p(X \rightarrow E)$, is the probability for mistaking a transmit \mathbf{x} for another matrix \mathbf{e} . It depends on the distance between the two matrices after transmission through the fading and noisy channel. The upper bound of PEP is used instead as the index of code performance.

PEP is minimised when STTC achieved full diversity (i.e. full rank) and high coding gain. Full diversity is achieved when the distance or difference matrix has full rank for all the codewords. STTC has a full rank if the distance or difference matrix between any codewords has full rank equals to the number of transmit antenna, n_T . STTC design that guarantees full diversity is based on these two heuristics design rules [9, 12, 14, 18], which are:

- Diverging branches from the same node differ in the second symbol while remaining constant in the first symbol.
- Merging branches differ in the first symbol but stays constant in the second symbol.

Since a two transmit antenna model has been used in this paper and the maximum rank is equal to two, the STTC in this paper can be considered to achieve full diversity. The rank order of this code must be

two, since any pair of codewords for the two rows of the difference matrix are linearly independent. This agrees with the first rule such that $(e_{t-1}^1 - x_{t-1}^1) = 0$ and $(e_{t-1}^2 - x_{t-1}^2) \neq 0$; and the second rule which is $(e_{t-1}^1 - x_{t-1}^1) \neq 0$ and $(e_{t-1}^2 - x_{t-1}^2) = 0$. Therefore, the difference matrix, $\mathbf{B}(\mathbf{x}, \mathbf{e})$ will have the form as in Equation 1 [9, 10, 19]:

$$B(x, e) = \begin{bmatrix} 0 & * \dots * & e_t^1 - x_t^1 \\ e_1^2 - x_1^2 & * \dots * & 0 \end{bmatrix} \tag{1}$$

To achieve the minimum error probability, minimum rank and minimum product of all eigenvalues of distance matrix $\mathbf{A}(\mathbf{x}, \mathbf{e}) = \mathbf{B}^H(\mathbf{x}, \mathbf{e}) \mathbf{B}(\mathbf{x}, \mathbf{e})$ should be maximised. The design criterion focuses on maximising the minimum coding gain, which is established on the combinations of all \mathbf{x} and \mathbf{e} . The coding gain distance (CGD) between the coded sequences \mathbf{x} and \mathbf{e} is defined as $\mathbf{d}^2(\mathbf{x}, \mathbf{e}) = \det(\mathbf{A}(\mathbf{x}, \mathbf{e}))$ where $\det(\cdot)$ is the determinant operator. Generator matrix \mathbf{G} is used to facilitate the code search procedure (i.e. through RDC) to obtain an optimal STTC (i.e full diversity and high coding gain). High coding gain is obtained by maximising the minimum determinant. Consequently, techniques in evaluating generator matrix \mathbf{G} is crucial in calculating the minimum determinant effectively to obtain high coding gain [3-5, 7, 11-15, 18].

3. Generator matrix G

Generator matrix \mathbf{G} will define the STTC encoder structure [10], where the branch coefficients are arranged alternatively in the generator matrix as in Equation 2.

$$G = \begin{bmatrix} g_{0,1}^1 & g_{0,1}^2 & g_{1,1}^1 & g_{1,1}^2 \\ g_{0,2}^1 & g_{0,2}^2 & g_{1,2}^1 & g_{1,2}^2 \end{bmatrix}^T \tag{2}$$

In this study, the QPSK STTC encoder with two transmit antennas model is used. Figure 1 illustrates the QPSK STTC encoder structure. It is shown in Figure 1 that generator matrix \mathbf{G} is the multiplying factor to the current input bit and the stored bit in the encoder structure. This is further described in Equation 3 [8-10].

$$x_t^i = \sum_{k=1}^2 \sum_{j=0}^{v_k} g_{j,i}^k c_{t-j}^k \quad \text{mod } 4, \quad i = 1, 2 \tag{3}$$

Upon multiplication with the generator matrix \mathbf{G} (as in Equation 3), the binary digits (input and stored bit) will be converted into non-binary output (the space-time modulated symbol), which are then used to obtain the trellis diagram. This is shown in Figure 2.

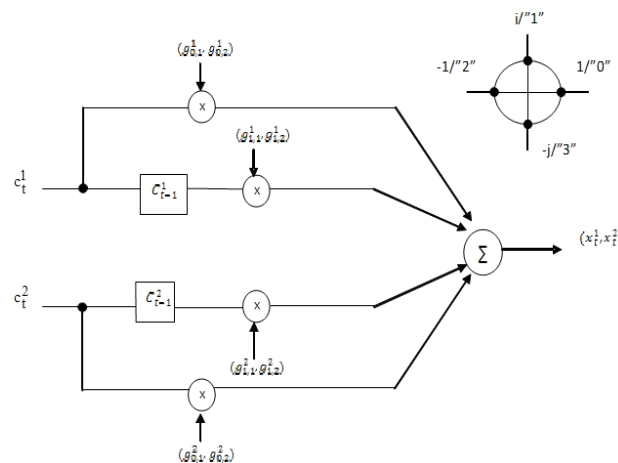

Figure 1. QPSK STTC encoder structure

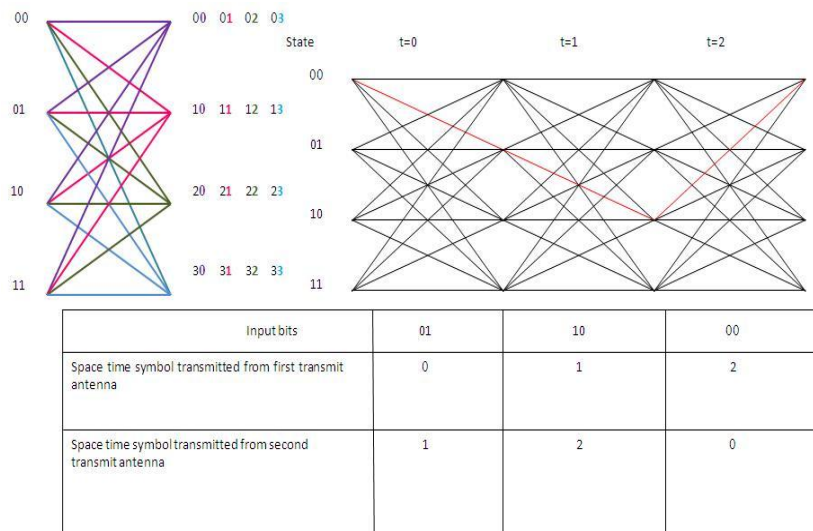

Figure 2. Continuous path through the trellis that defines the transmitted symbols [9]

As illustrated in Figure 2, path movement of the input bits can be traced with the help of the trellis diagram. Defining the path movement is significant in order to minimize the error probability (hence minimum determinant) [3, 5, 8, 10]. The optimal STTC is the one that minimizes the error probability. Hence generator matrix G is used to facilitate the code search procedure to obtain an optimal STTC.

4. Different generator matrices G of similar state

Realizing the importance of the generator matrix G in producing optimal STTC, a few techniques have been developed in producing the generator matrix G [3-9, 12-15]. The focus thus far is on the STTC performance analysis for different states, such as 4, 8, 16 and 32 states. For example, it has been found that as the number of states increases, the STTC performance improves [6]. So far, there is no effort yet in producing a few generator matrices G with different minimum determinants within the same state. In this study, a few generator matrices G with different minimum determinants, namely four (4), eight (8) and also sixteen (16) of the 4-state QPSK, have been produced to analyse the BER and SNR performance of STTC. The generation of the generator matrices G for minimum determinant eight (8) and sixteen (16) was done using Lisy tree structure [5]. Table 1 shows the summary of the generator matrix G that was used in this paper.

Table 1. Summary of generator matrices G with their minimum determinant

Code	Generator Matrix G	Determinant	Code	Generator Matrix G	Determinant
Tarokh <i>et al.</i> [9]	$G = \begin{pmatrix} 0 & 0 & 2 & 1 \\ 2 & 1 & 0 & 0 \end{pmatrix}$	4.0	Baro <i>et al.</i> [12]	$G = \begin{pmatrix} 2 & 0 & 1 & 3 \\ 2 & 2 & 0 & 1 \end{pmatrix}$	8.0
Tao <i>et al.</i> [15]	$G = \begin{pmatrix} 0 & 2 & 1 & 2 \\ 2 & 1 & 2 & 0 \end{pmatrix}$	4.0	Lisya16-31 [5]	$G = \begin{pmatrix} 0 & 0 & 1 & 2 \\ 0 & 0 & 2 & 0 \end{pmatrix}$	16.0
Bahador [16]	$G = \begin{pmatrix} 0 & 2 & 1 & 2 \\ 2 & 3 & 2 & 0 \end{pmatrix}$	4.0	Lisya16-63 [5]	$G = \begin{pmatrix} 0 & 0 & 2 & 1 \\ 0 & 0 & 0 & 2 \end{pmatrix}$	16.0
Lisya8-2 [5]	$G = \begin{pmatrix} 3 & 3 & 3 & 0 \\ 1 & 3 & 1 & 1 \end{pmatrix}$	8.0	Lisya16-100 [5]	$G = \begin{pmatrix} 0 & 0 & 3 & 2 \\ 0 & 0 & 2 & 0 \end{pmatrix}$	16.0
Yuan <i>et al.</i> [17]	$G = \begin{pmatrix} 0 & 2 & 1 & 0 \\ 2 & 2 & 0 & 1 \end{pmatrix}$	8.0			

A two-transmit antenna model has been used, with number of iterations for this simulation is 1000 for each generator matrices G . The same random data is applied throughout the simulation process for each generator matrices G . The flow chart in analysing the generator matrices G of similar state but with varying minimum determinants is shown in Figure 3.

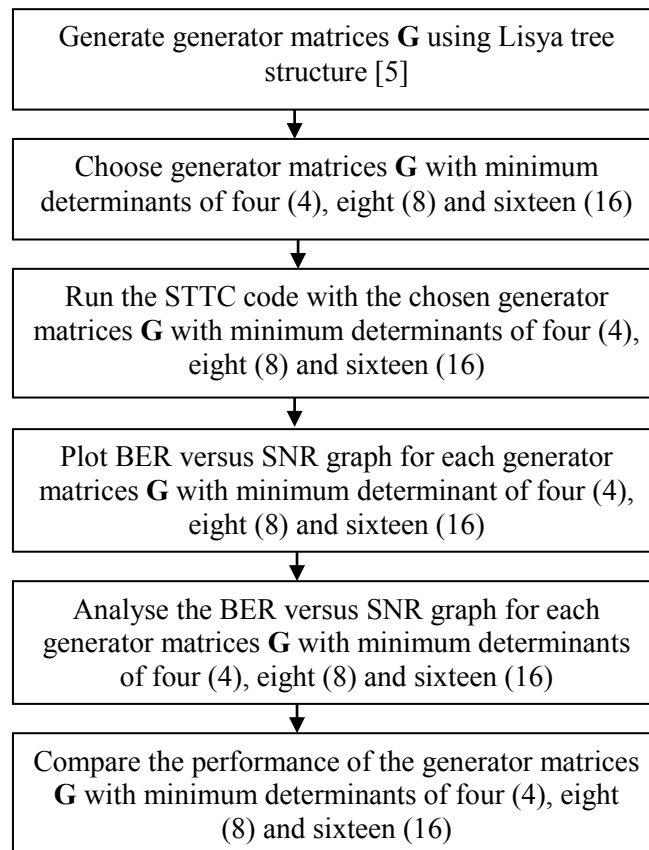

Figure 3. Flow chart in analysing generator matrices G of similar state but varying minimum determinants

5. Results and discussion

The performance of Tarokh [9], Baro [12] and Lisya16-31 [5] for minimum determinant of four (4), eight (8) and sixteen (16) is illustrated in Figure 4. The details of the generator matrix G can be found in Table 1. It is shown in Figure 4 that the BER for Lisya16-31 with the minimum determinant of 16 is comparatively lower than Baro with the minimum determinant of 8. The result is significant since with the same kind of errors, Lisya16-31 can send more data (i.e. four times more as compared to Baro). Hence Lisya16-31 should be preferred compared to Baro. Usually, the BER of generator matrices G with smaller minimum determinant is comparatively lower than those of higher minimum determinant.

BER versus SNR performance for Bahador [11], Lisya8-2 [5] and Lisya16-100 [5] for minimum determinant of four (4), eight (8) and sixteen (16) is found in Figure 5. Again, it is clearly presented in Figure 5 that the BER for Lisya16-100 with the minimum determinant of 16 is comparatively lower than Lisya8-2 with the minimum determinant of 8. This implies that Lisya 16-100 can send more data as compared to Lisya 8-2.

From Figure 6, it is also shown that the generator matrix output for Yuan [17] with the minimum determinant of 8 has a higher BER value compared to Lisya16-63 [5] with the minimum determinant of 16. The result is consistent with Figure 4 and 5, which justifies that the generator matrices G with the minimum determinant 16 from Lisya tree structure perform better, particularly at high SNR value (i.e. at SNR > 12).

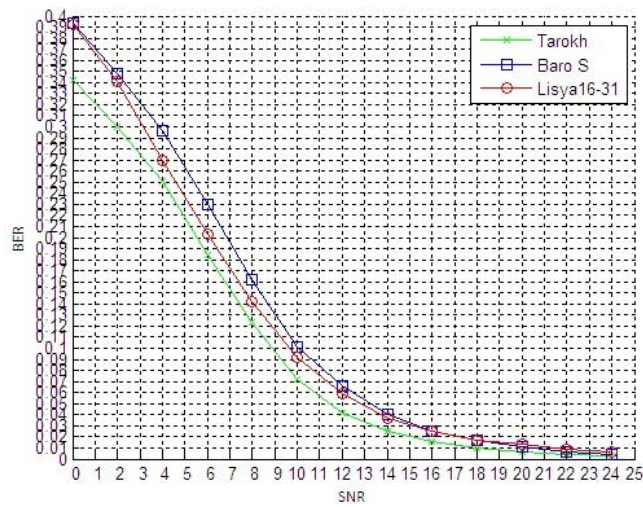

Figure 4. A graph of BER vs SNR performance for Tarokh [9], Baro [12] and Lisyas16-31 [5], with minimum determinant of four (4), eight (8) and sixteen (16)

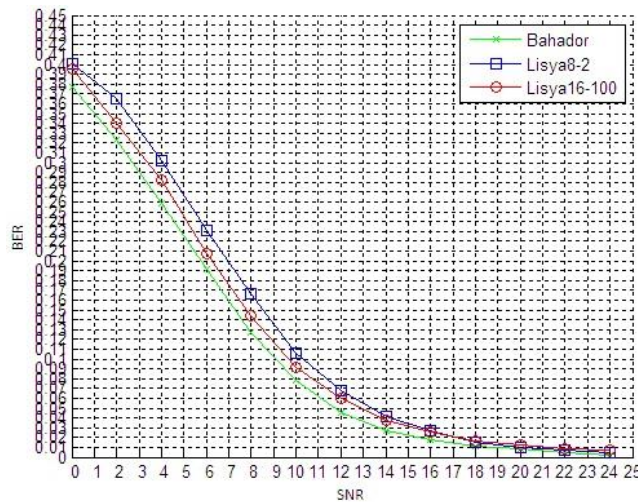

Figure 5. A graph of BER vs SNR performance for Bahador [16], Lisyas8-2 [5] and Lisyas16-100 [5], with minimum determinant of four (4), eight (8) and sixteen (16)

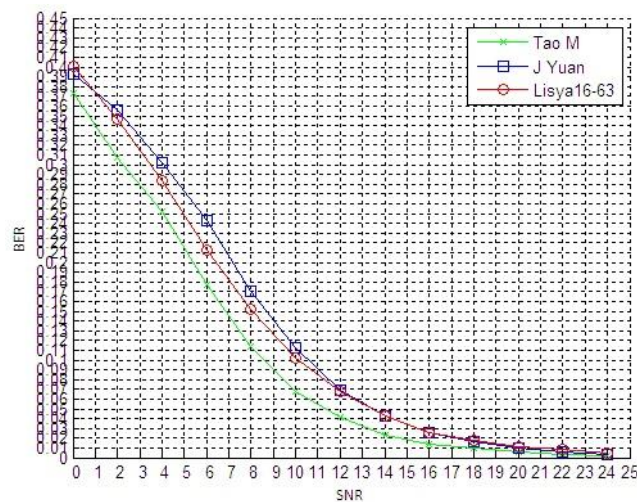

Figure 6. A graph of BER vs SNR performance for Tao [14], Yuan [17] and Lisyas16-63 [5], with minimum determinant of four (4), eight (8) and sixteen (16)

6. Conclusions

This paper compares the performance of different generator matrices G at the same state. It provides an analysis of how the generator matrices of varying minimum determinants would behave when the transmission is established in a similar state of trellis. With different generator matrices G , how would it impact BER and SNR. This research is imperative since no effort has been done yet to evaluate the performance of generator matrix G within the same state. So far, the evaluation is on different states. It is found that the generator matrix G with higher minimum determinant produced by the Lisy tree structure performs better compared to the other generator matrices with lower minimum determinant, especially at higher SNR (i.e., $\text{SNR} > 12$). This research can be used as a platform for future studies that employ multiple receiving antennas.

References

- [1] Simon M K and Alouini M S 2000 *Digital communication over fading channels: a unified approach to performance analysis* (United Kingdom: John Wiley and Sons)
- [2] Rappaport T S 2002 *Wireless communications: principles and practice* (USA: Prentice-Hall)
- [3] Harun H, Dimiyati K and Ungku Chulan U A 2013 *Aerospace Science and Technology* **24** 136-40
- [4] Harun H, Ungku Chulan U A and Khazani K 2011 *15th International Conference on Information Visualization*
- [5] Harun H 2010 *An improved algorithm for fast evaluation of space-time trellis code (STTC) generator matrix* PhD Thesis University of Malaya, Malaysia
- [6] Yuen N 2003 *Performance analysis of space-time trellis codes* MEng Thesis University of British Columbia, Canada
- [7] Banerjee S and Agrawal M 2013 *Wireless Personal Communications* **75** 1141-54
- [8] Tarokh V, Seshadri N and Calderbank A R 1997 *IEEE International Conference on Communications*
- [9] Tarokh V, Seshadri N and Calderbank A R 1998 *IEEE Transactions on Information Theory* **44** 744-65
- [10] Vucetic B and Yuan J 2003 *Space-time coding* (United Kingdom: John Wiley and Sons).
- [11] Harun H, Ungku Chulan U A I and Ungku Chulan U A 2013 *IEEE Computing, Communications and IT Applications Conference*
- [12] Baro S, Bauch G and Hansmann A *Communications Letters* **4** 20-2
- [13] Abdool-Rassool B, Nakhai M R, Heliot F, Revelly L and Aghvami H 2004 *IEE Proceeding on Communications* **151** 25-31
- [14] Yuan J, Vucetic B, Chen Z and Firmanto W 2003 *IEEE Transactions on Communications* **51** 1991-6
- [15] Tao M and Cheng R S 2001 *IEEE Communications Letters* **5** 313-5
- [16] Amiri B 2006 *Space-time trellis codes*
- [17] Yuan J, Vucetic B, Xu B and Chen Z 2001 *IEEE Vehicular Technology Conference*
- [18] Fukuda T, Otsu S, Tokunaga Y and Zhao H 2008 *23rd International Technical Conference on Circuits/Systems, Computers and Communications*
- [19] Jankiraman M 2004 *Space-time Codes and MIMO Systems* (USA: Artech House)